

**355201**

1307 gr./m.

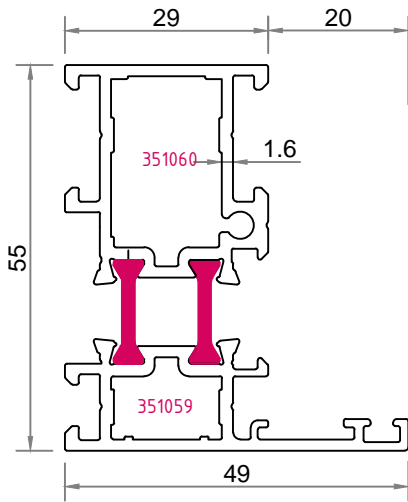

lx : 15,82 cm<sup>4</sup>  
ly : 5,09 cm<sup>4</sup>

**355202**

1486 gr./m.

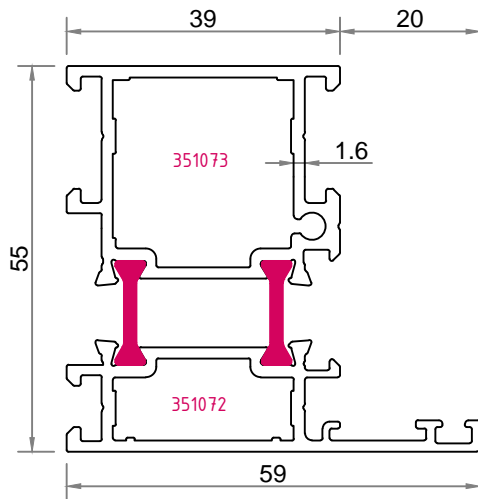

lx : 18,70 cm<sup>4</sup>  
ly : 9,97 cm<sup>4</sup>

**355203**

1656 gr./m.

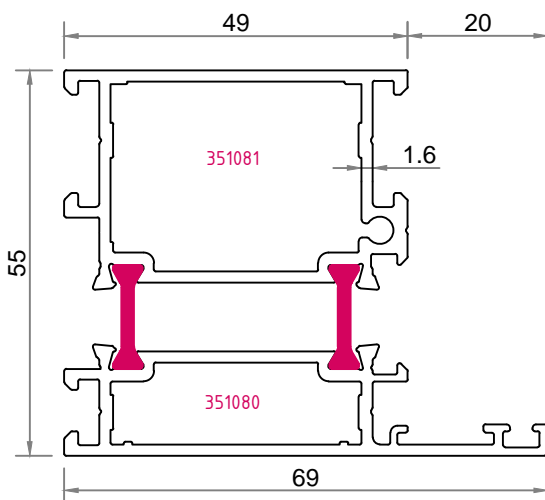

lx : 22,38 cm<sup>4</sup>  
ly : 16,21 cm<sup>4</sup>

**355204**

1719 gr./m.

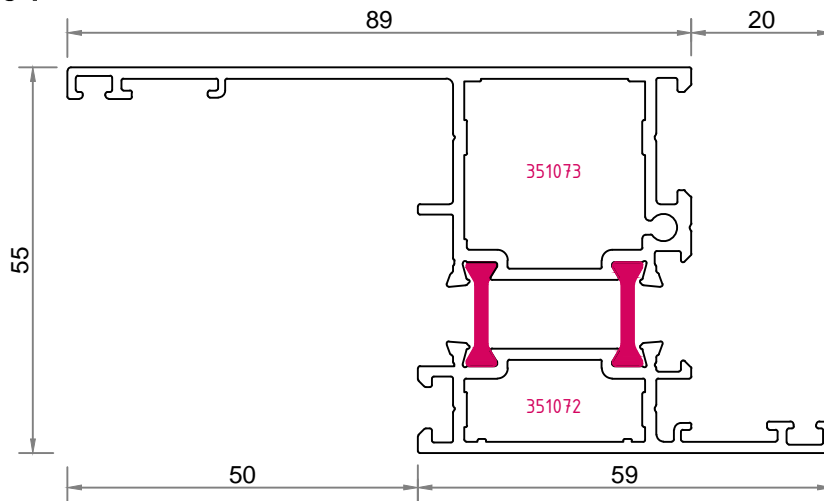

lx : 13,67 cm<sup>4</sup>  
ly : 42,64 cm<sup>4</sup>

**355205**

1607 gr./m.

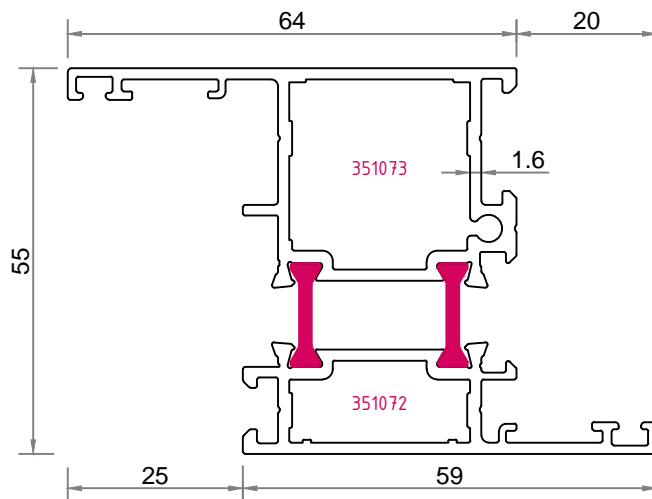

lx : 27,03 cm<sup>4</sup>  
ly : 11,48 cm<sup>4</sup>

**355206**

1807 gr./m.

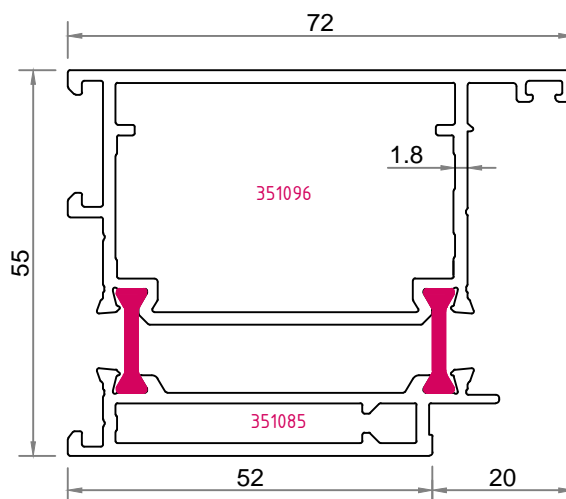

lx : 35,04 cm<sup>4</sup>  
ly : 50,91 cm<sup>4</sup>

**355207**

1804 gr./m.

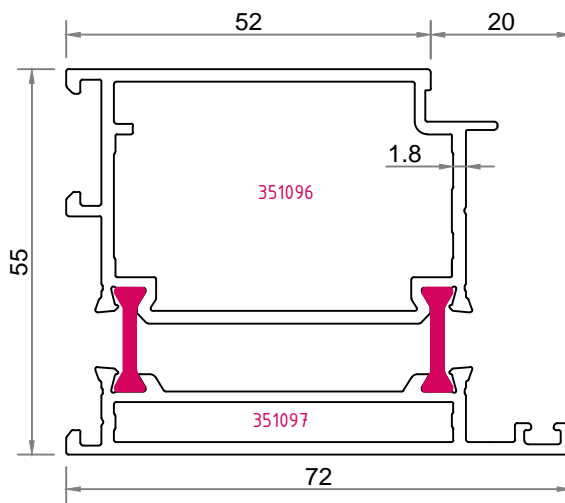

lx : 35,04 cm<sup>4</sup>  
ly : 50,91 cm<sup>4</sup>

**355241**

1290 gr./m.

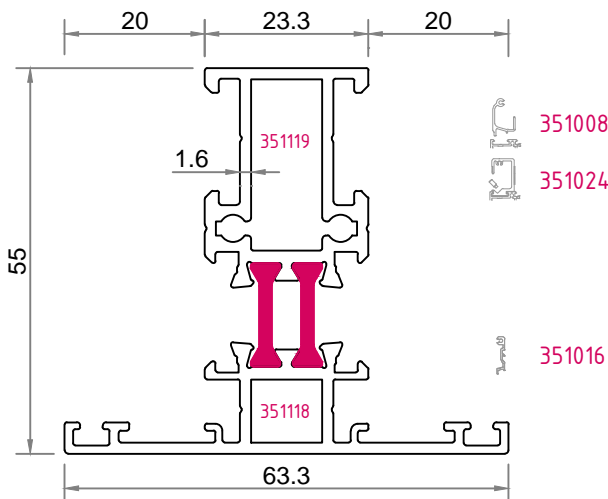

lx : 15,07 cm<sup>4</sup>  
ly : 6,20 cm<sup>4</sup>

**355242**

1447 gr./m.

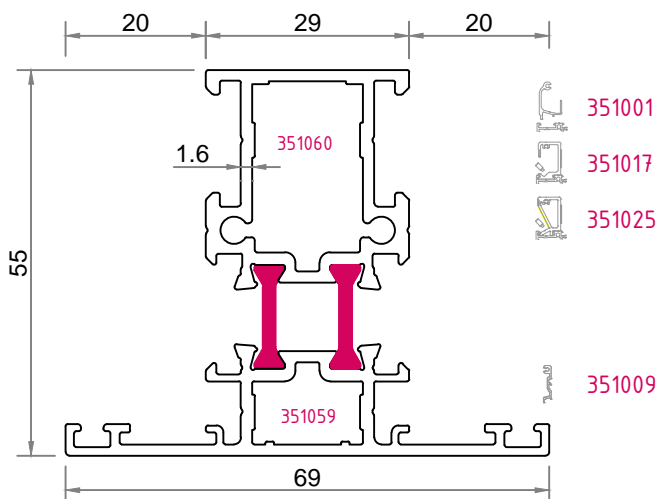

lx : 17,11 cm<sup>4</sup>  
ly : 8,93 cm<sup>4</sup>

**355243**

1625 gr./m.

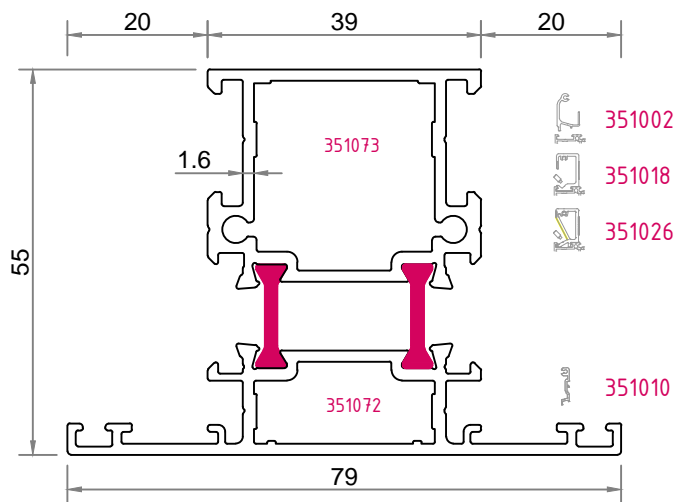

$I_x : 19,60 \text{ cm}^4$   
 $I_y : 15,62 \text{ cm}^4$

**355244**

1804 gr./m.

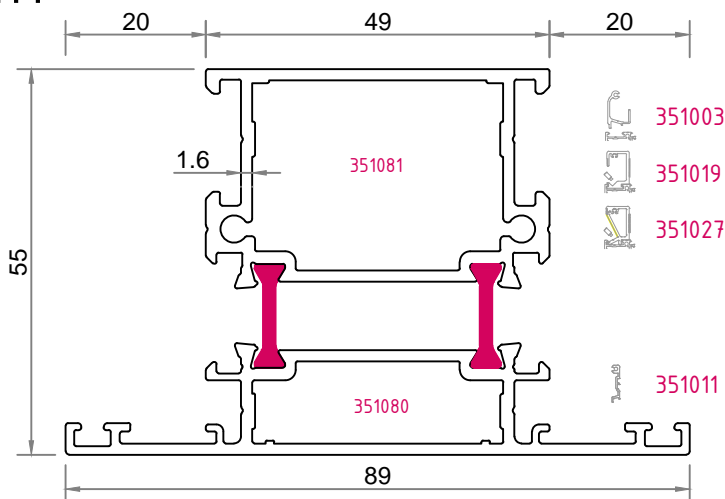

$I_x : 22,09 \text{ cm}^4$   
 $I_y : 25,05 \text{ cm}^4$

**355245**

2305 gr./m.

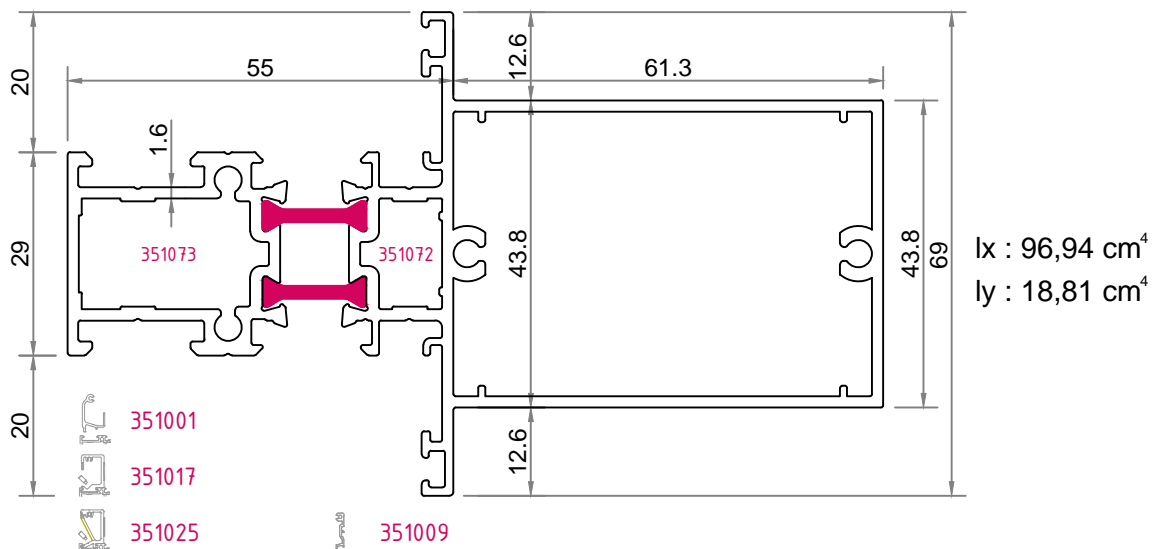

$I_x : 96,94 \text{ cm}^4$   
 $I_y : 18,81 \text{ cm}^4$



**355246**

1536 gr./m.

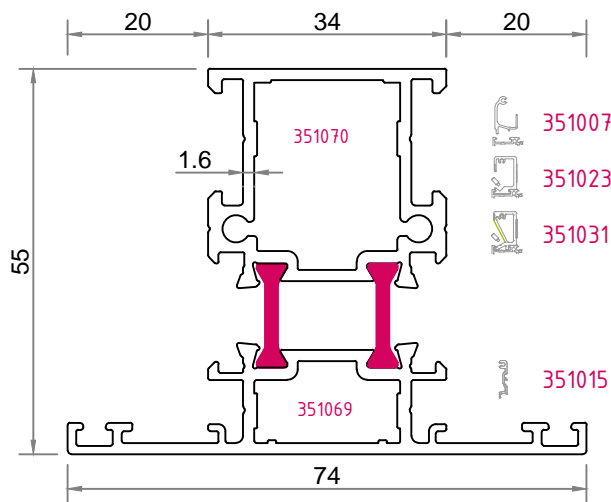

lx : 18,36 cm<sup>4</sup>  
ly : 11,95 cm<sup>4</sup>

**355247**

2171 gr./m.

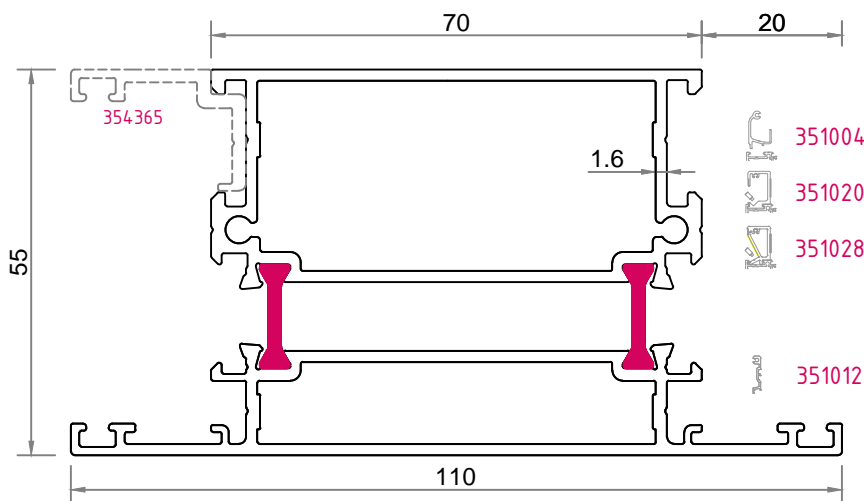

lx : 27,10 cm<sup>4</sup>  
ly : 55,01 cm<sup>4</sup>

**355211**

1267 gr./m.

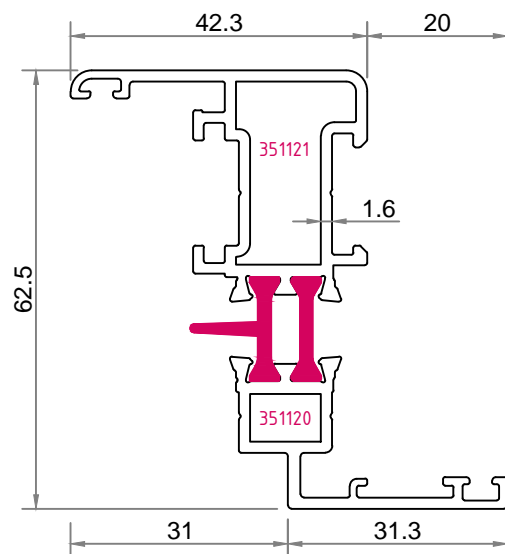

lx : 21,50 cm<sup>4</sup>  
ly : 3,50 cm<sup>4</sup>

**355212**

1284 gr./m.

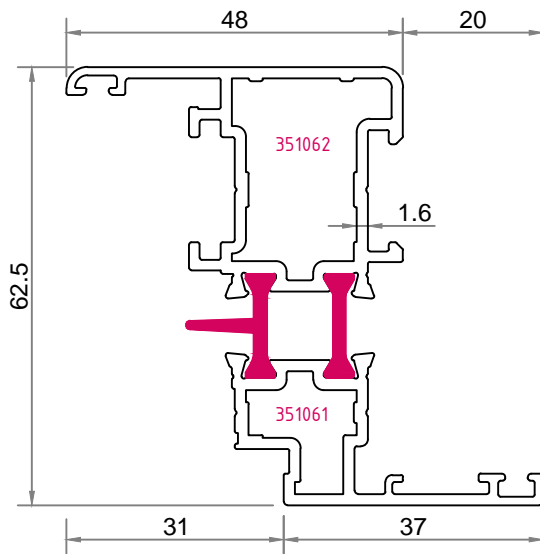

$I_x : 23,860 \text{ cm}^4$   
 $I_y : 5,233 \text{ cm}^4$

**355213**

1615 gr./m.

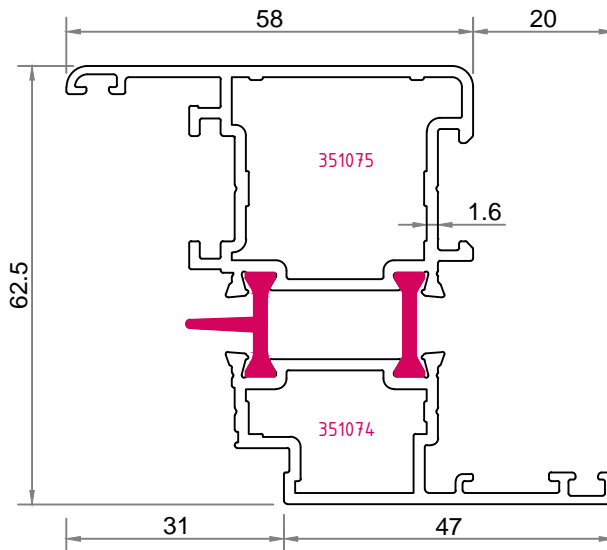

$I_x : 29,68 \text{ cm}^4$   
 $I_y : 10,11 \text{ cm}^4$

**355214**

1793 gr./m.

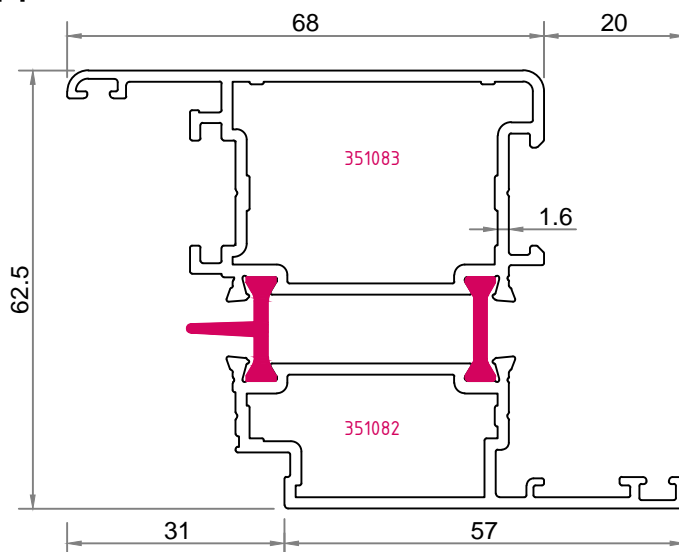

$I_x : 35,75 \text{ cm}^4$   
 $I_y : 16,14 \text{ cm}^4$

**355215**

1346 gr./m.

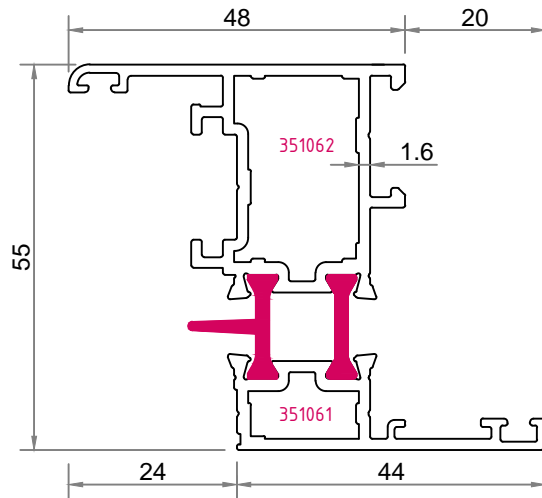

lx : 19,81 cm<sup>4</sup>  
ly : 5,25 cm<sup>4</sup>

**355216**

1574 gr./m.

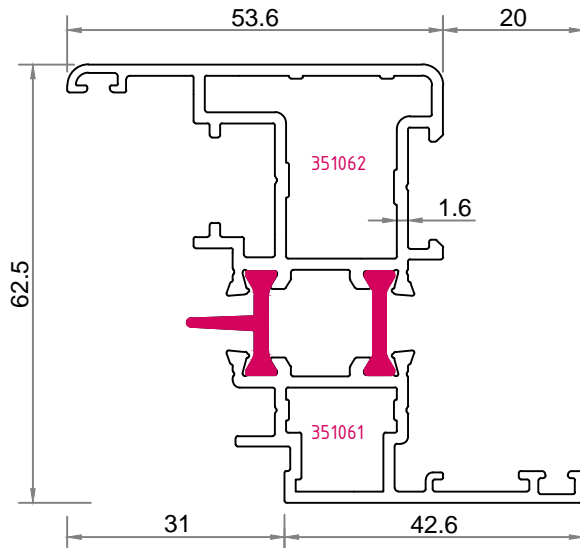

lx : 27,99 cm<sup>4</sup>  
ly : 7,49 cm<sup>4</sup>

**355217**

1752 gr./m.

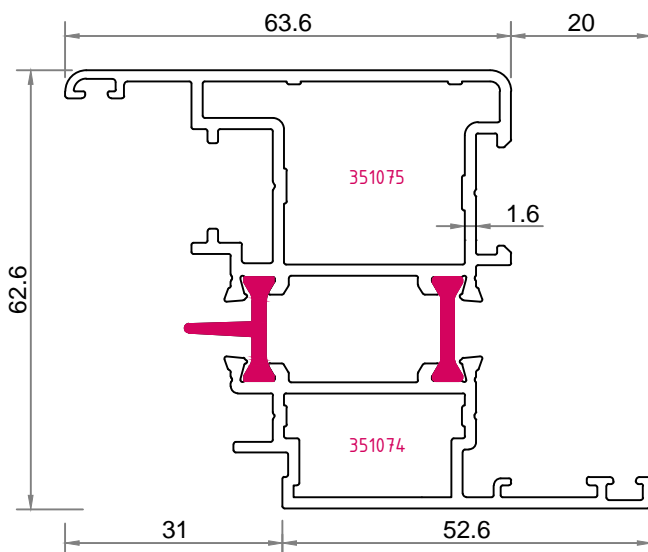

lx : 33,42 cm<sup>4</sup>  
ly : 12,92 cm<sup>4</sup>

**355218**

2234 gr./m.

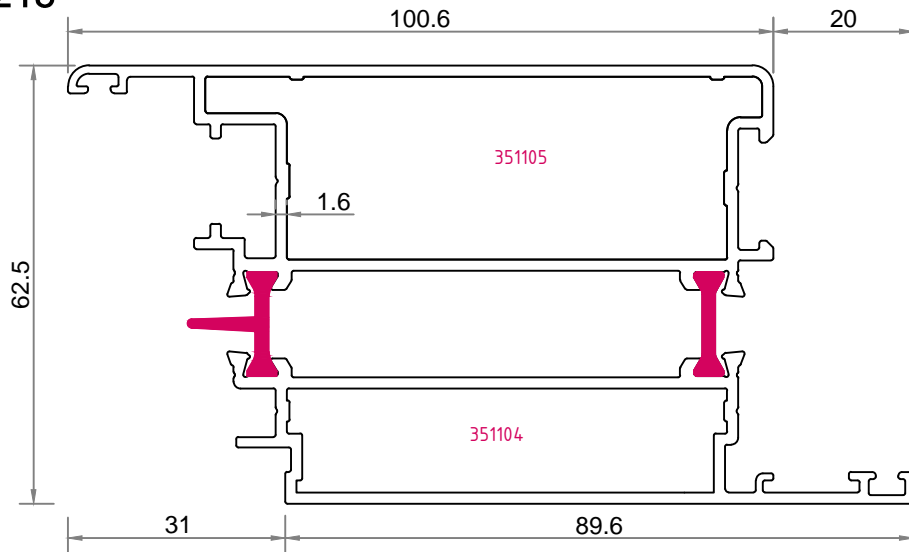

**355219**

2025 gr./m.

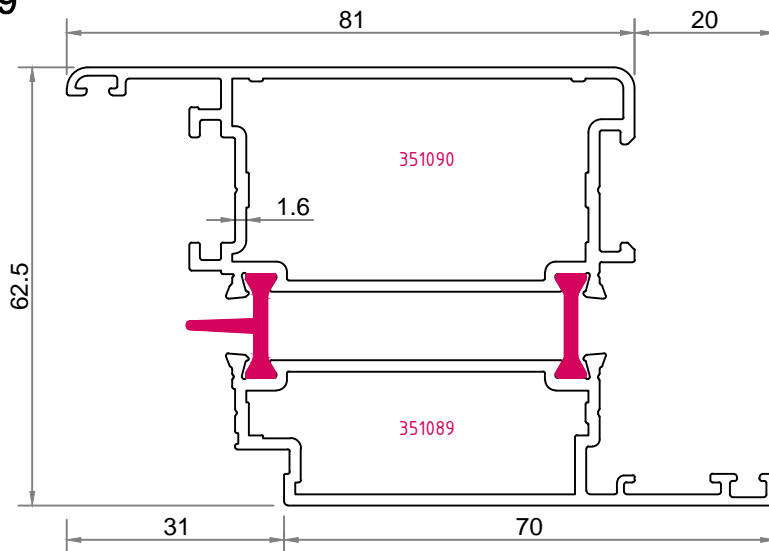

$I_x : 24,37 \text{ cm}^4$   
 $I_y : 47,74 \text{ cm}^4$

**355220**

2062 gr./m.

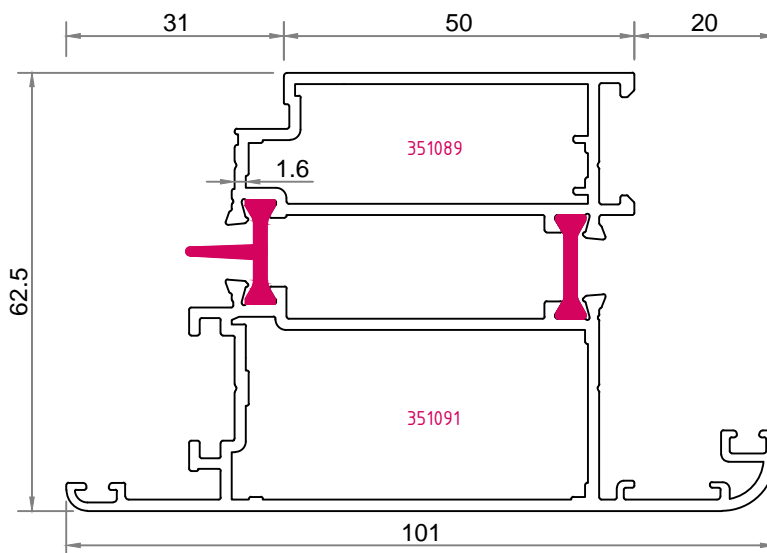

$I_x : 30,80 \text{ cm}^4$   
 $I_y : 42,57 \text{ cm}^4$

**355221**

2314 gr./m.

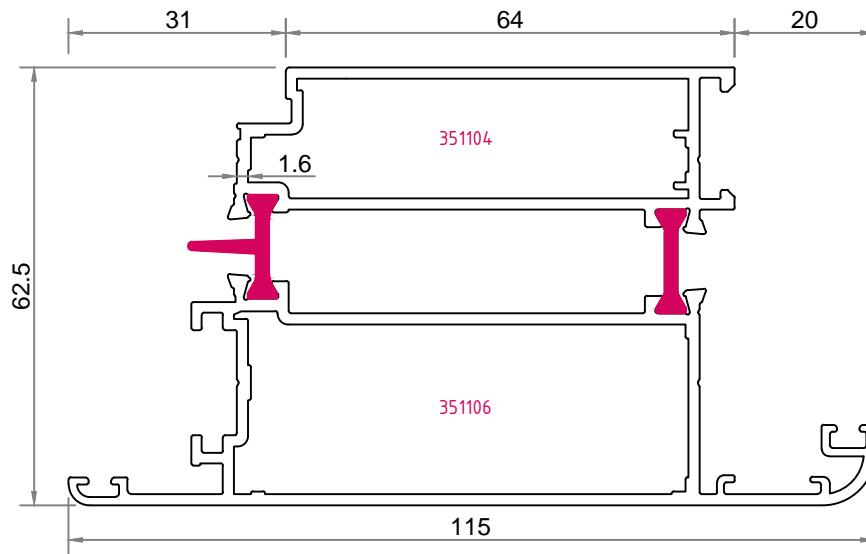

$I_x : 37,57 \text{ cm}^4$   
 $I_y : 67,74 \text{ cm}^4$

**355222**

1989 gr./m.

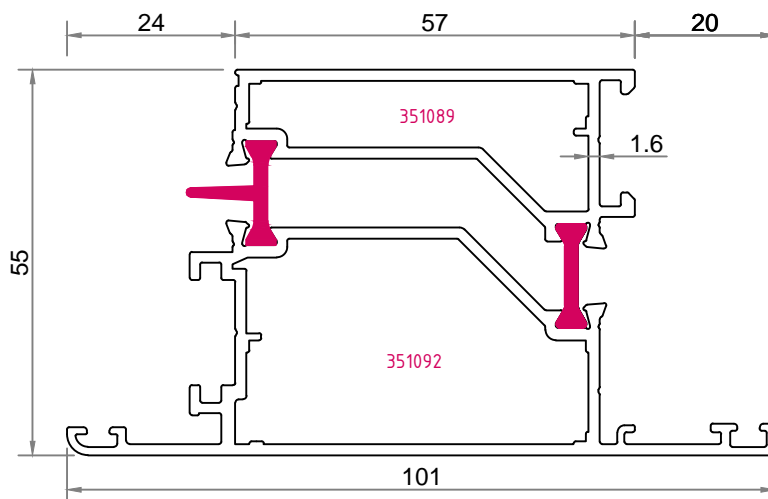

$I_x : 25,89 \text{ cm}^4$   
 $I_y : 38,04 \text{ cm}^4$

**355223**

2275 gr./m.

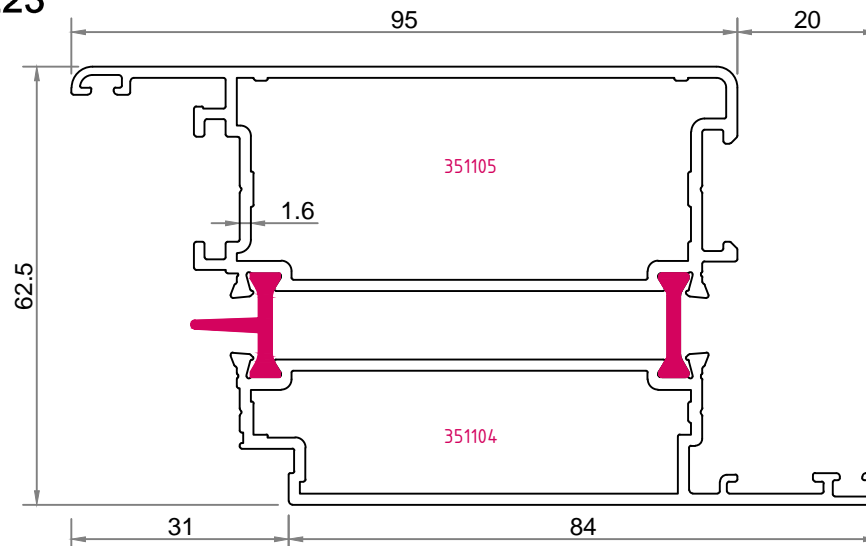

$I_x : 31,70 \text{ cm}^4$   
 $I_y : 68,65 \text{ cm}^4$

**355224**

1937 gr./m.

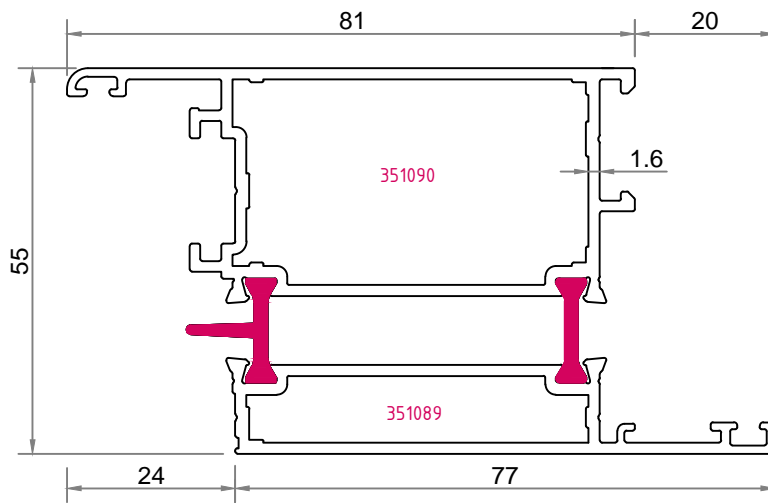

$I_x : 20,81 \text{ cm}^4$   
 $I_y : 42,72 \text{ cm}^4$

**355225**

1524 gr./m.

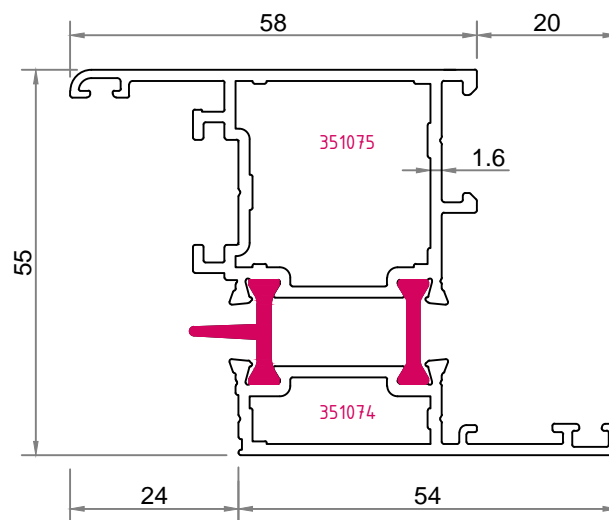

$I_x : 24,21 \text{ cm}^4$   
 $I_y : 9,45 \text{ cm}^4$

**355226**

2042 gr./m.

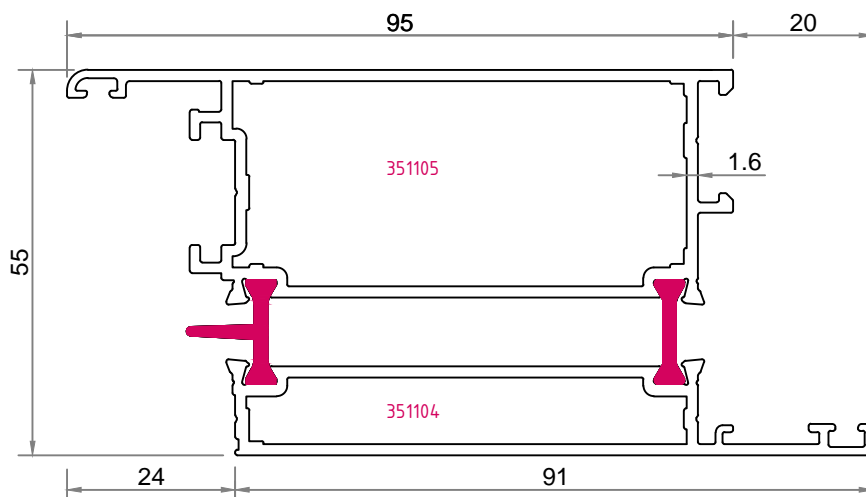

**355227**

2068 gr./m.

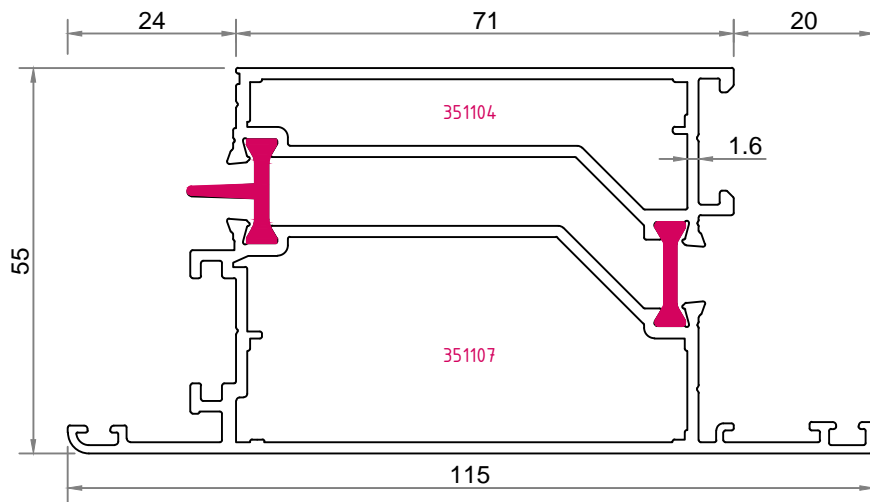

**355228**

1525 gr./m.

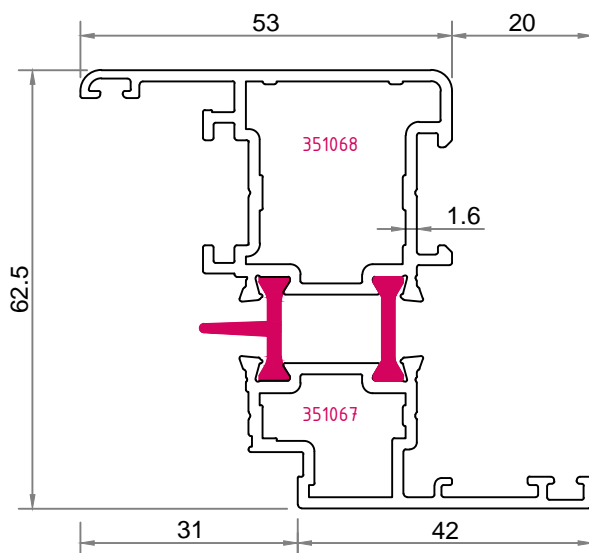

$I_x : 27,20 \text{ cm}^4$   
 $I_y : 7,58 \text{ cm}^4$

**355229**

2194 gr./m.

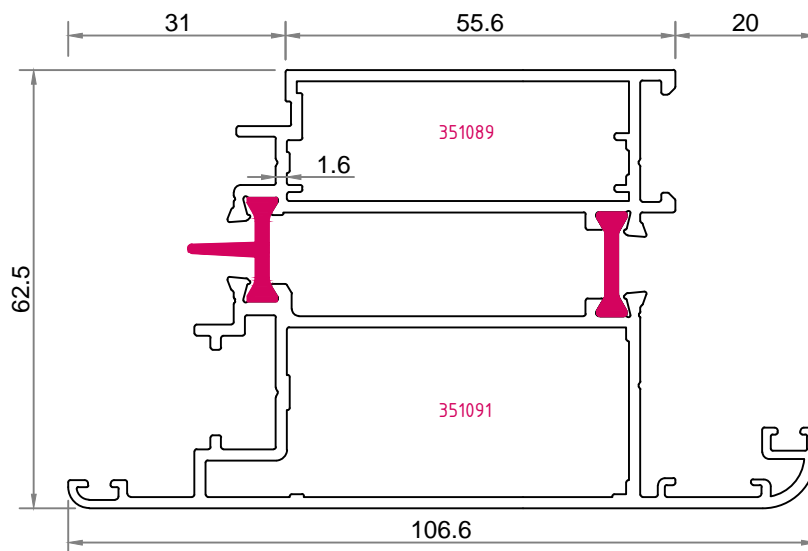

$I_x : 35,04 \text{ cm}^4$   
 $I_y : 50,91 \text{ cm}^4$

**355230**

1436 gr./m.

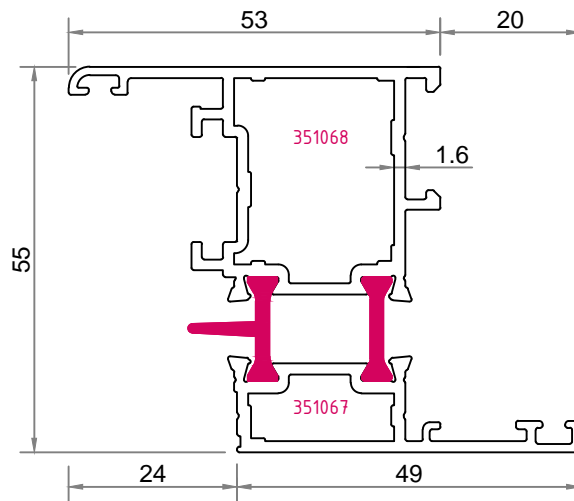

lx : 21,88 cm<sup>4</sup>  
ly : 7,20 cm<sup>4</sup>

**355231**

3380 gr./m.

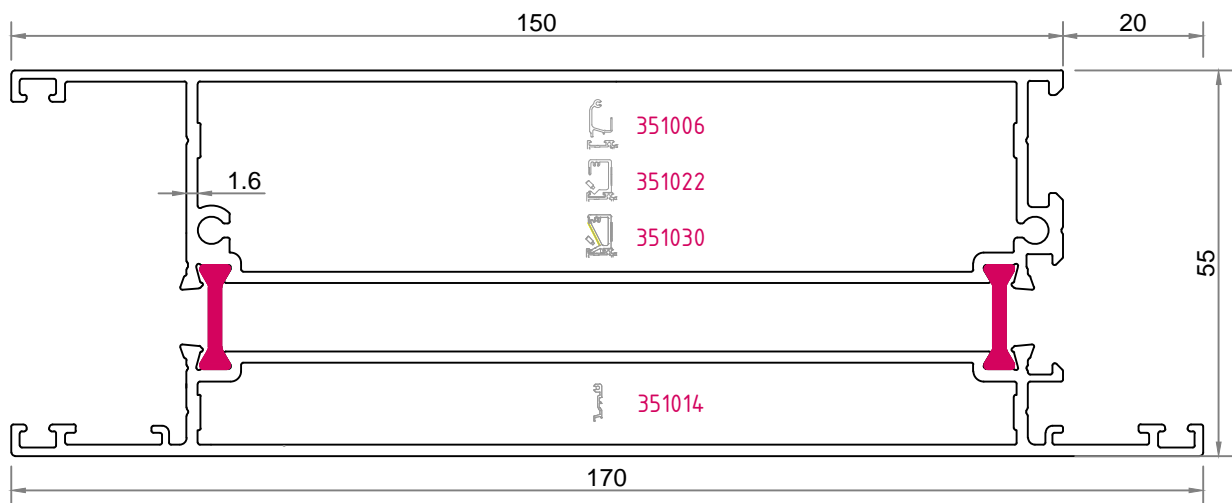

lx : 42,07 cm<sup>4</sup>  
ly : 250,21 cm<sup>4</sup>



**355232**

2545 gr./m.

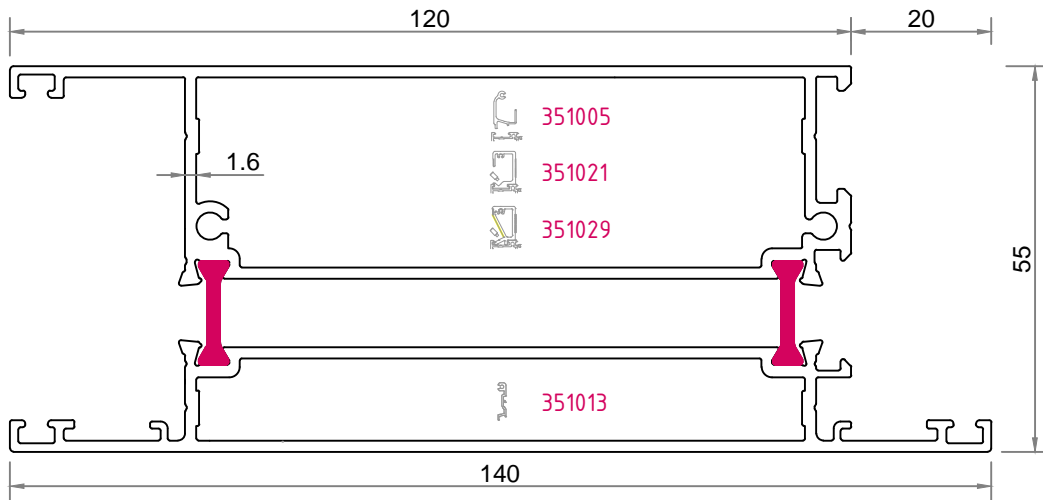

**355233**

1946 gr./m.

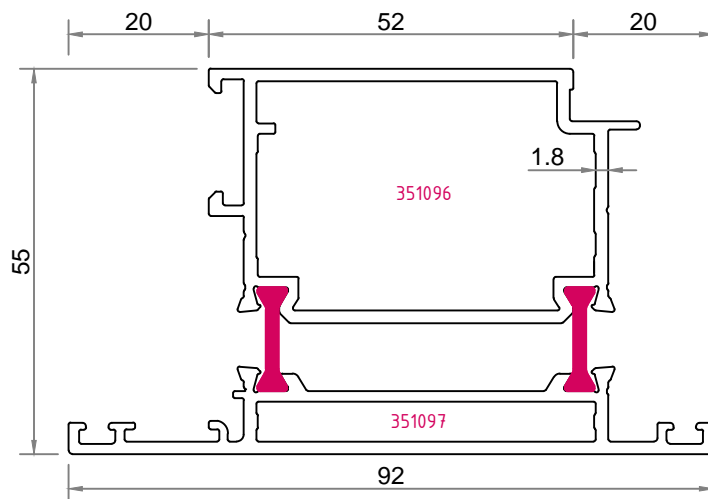

**353032**

368 gr./m.

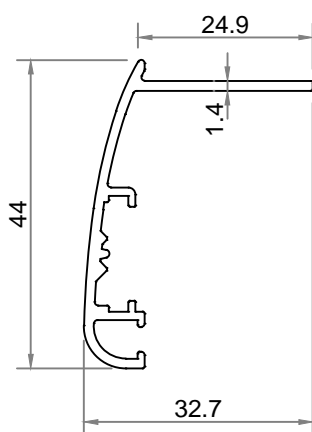

**353836**

672 gr./m.

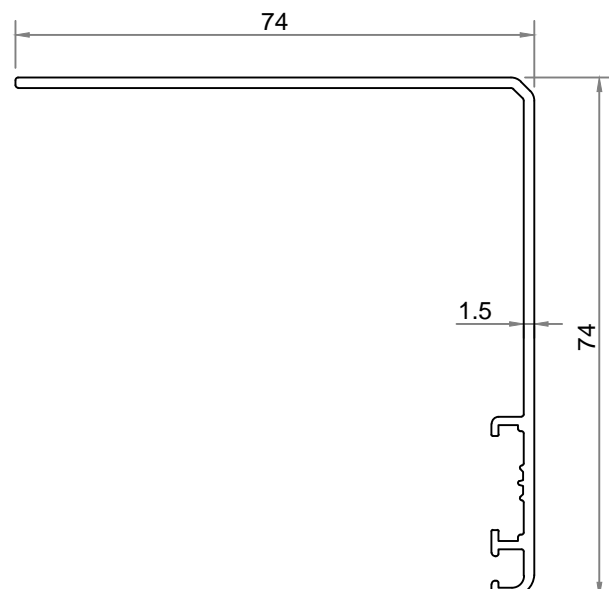

**355234**

1943 gr./m.

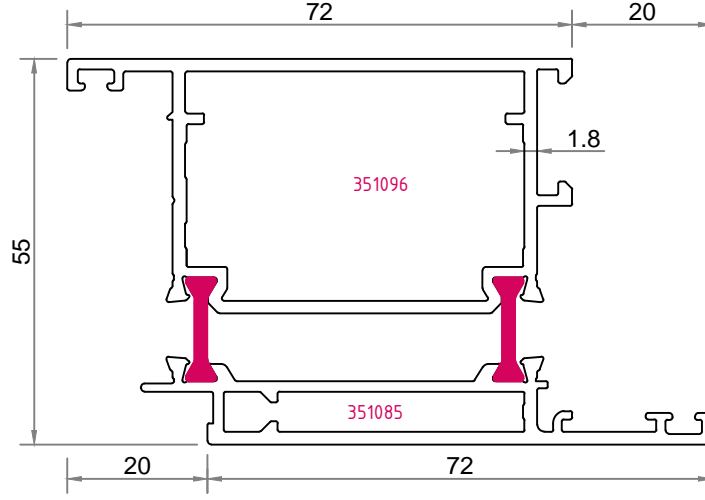

**353008** Arma sürme uyumlu açılır kasa

1406 gr./m.

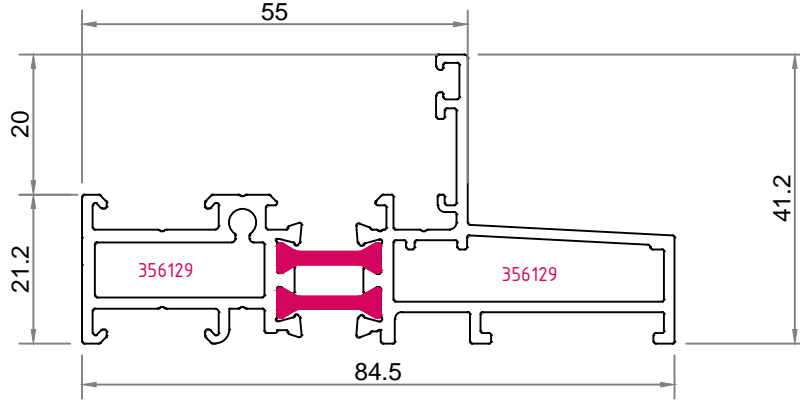

**353609** Moventis sürme uyumlu açılır kasa

1692 gr./m.

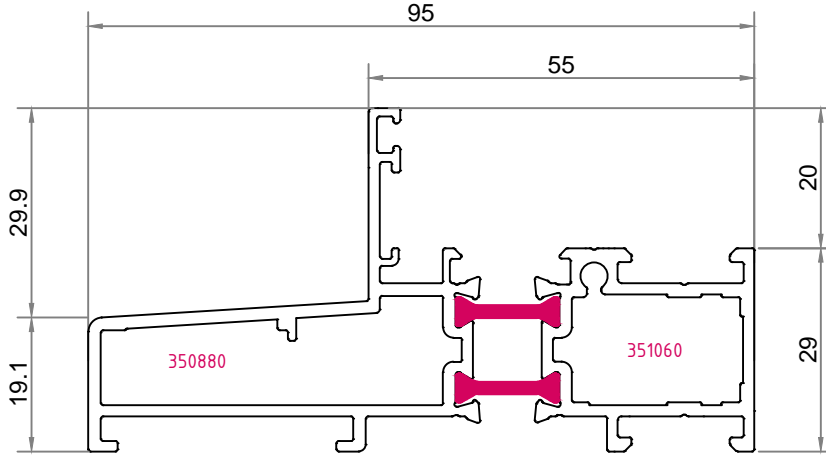

# IQ-2150 FORMO

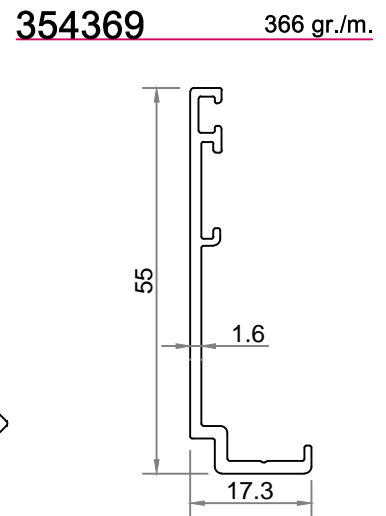
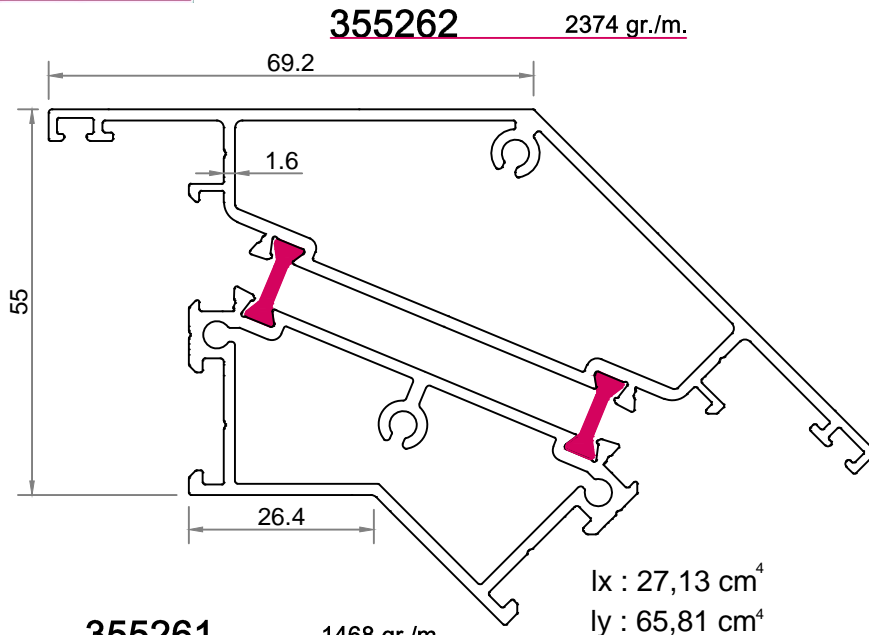

**355261** 1468 gr./m.

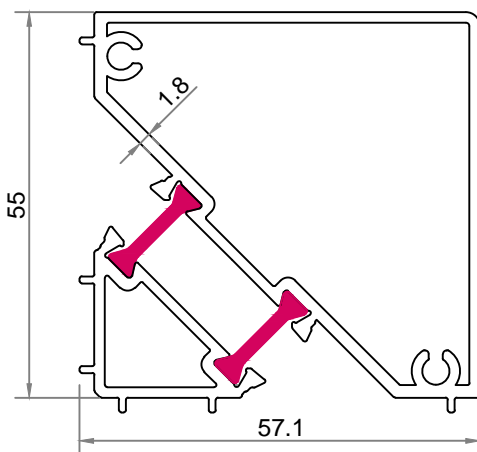

**354365** 234 gr./m.

**354366** 185 gr./m.

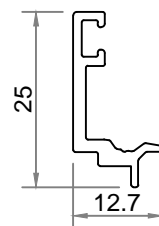
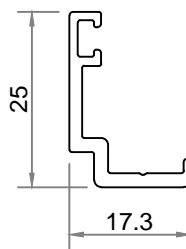

**355263** 1368 gr./m.

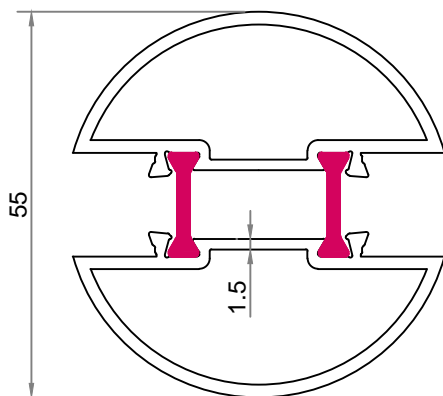

**355306** 1600 gr./m.

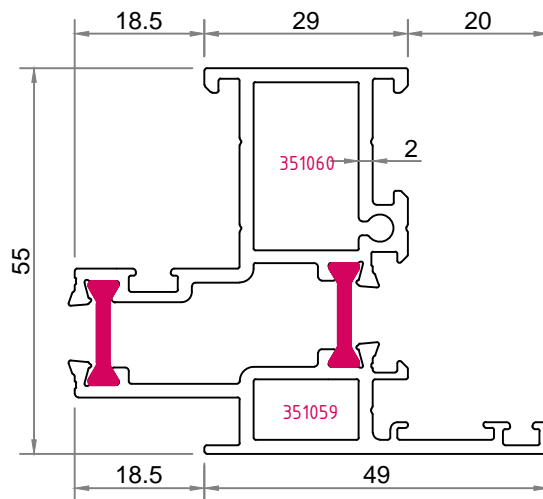

lx : 17,33 cm

ly : 12,04 cm

**355361** 1406 gr./m.

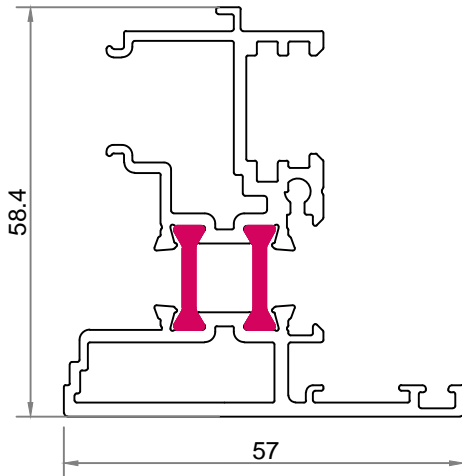

**355362** 1379 gr./m.

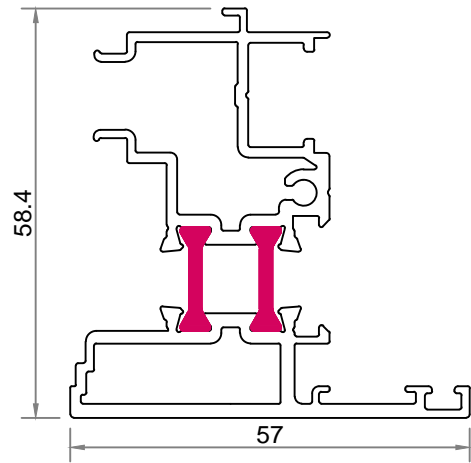

**355363** 1048 gr./m.

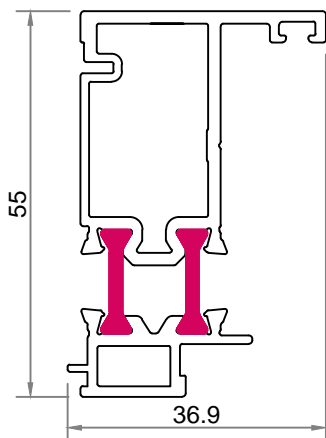

**355364** 1077 gr./m.

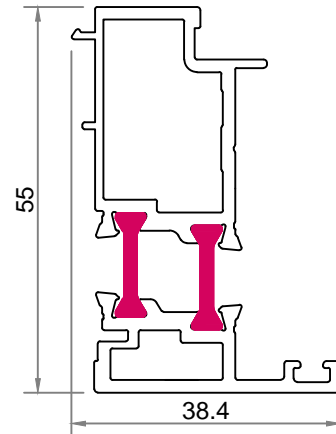

**355366** 782 gr./m.

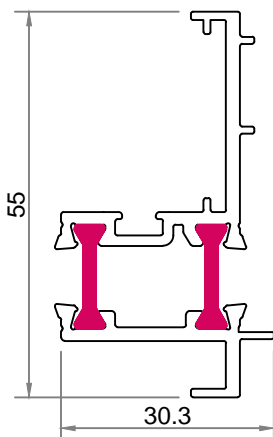

**355368** 340 gr./m.

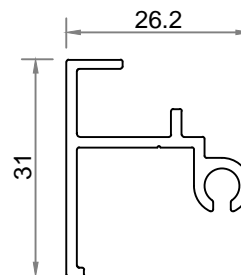

**355365** 1248 gr./m.

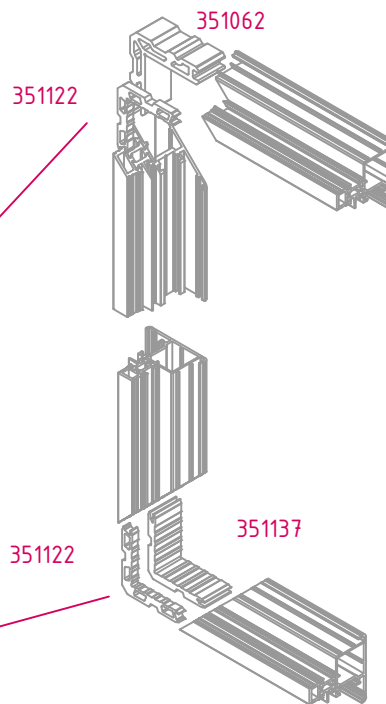
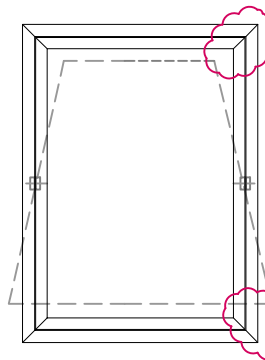
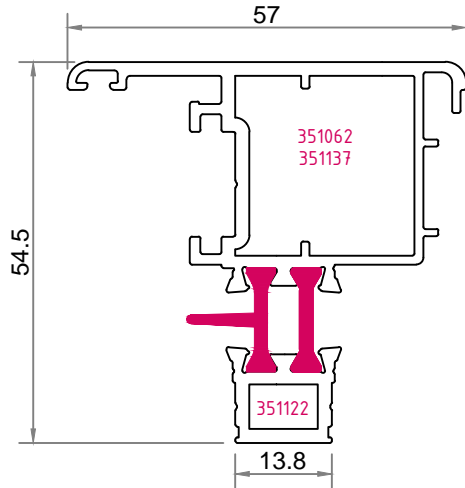

ALTERNATIVE 1



ALTERNATIVE 2



**355369** 1212 gr./m.

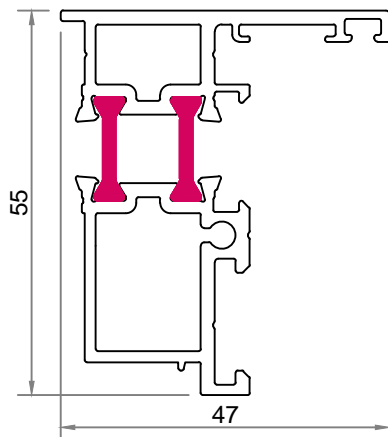

**355370** 509 gr./m.

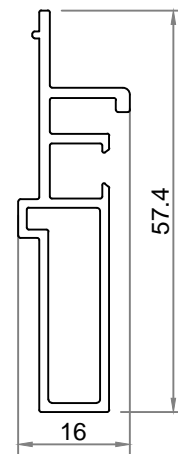

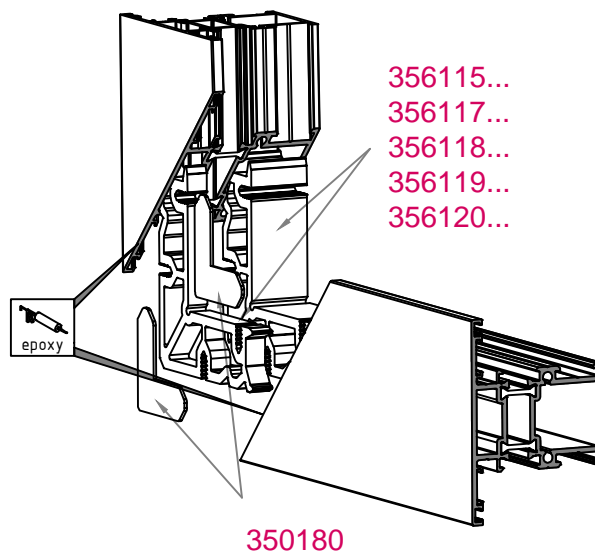
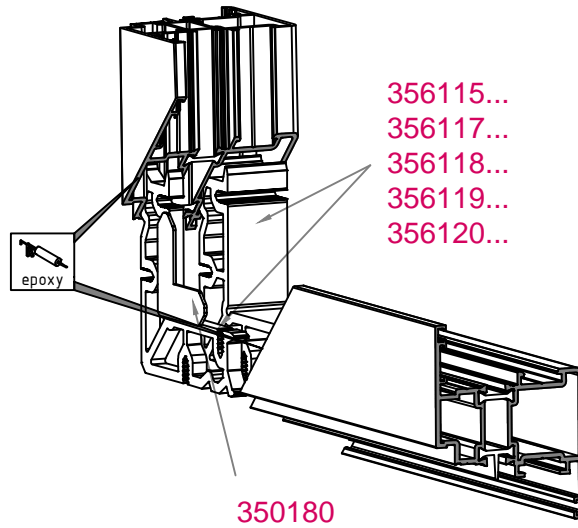
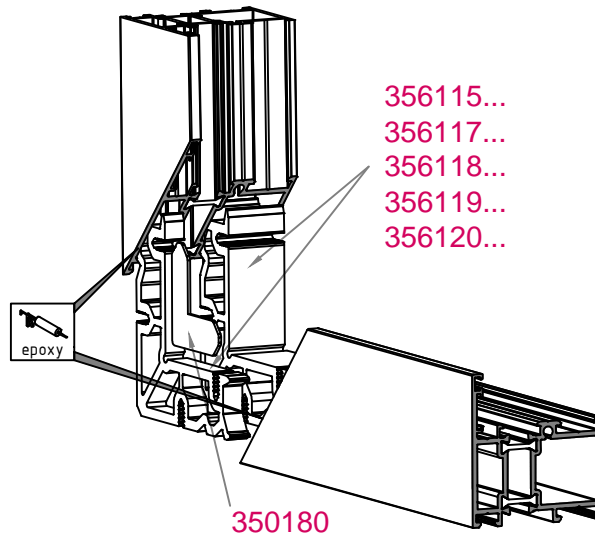

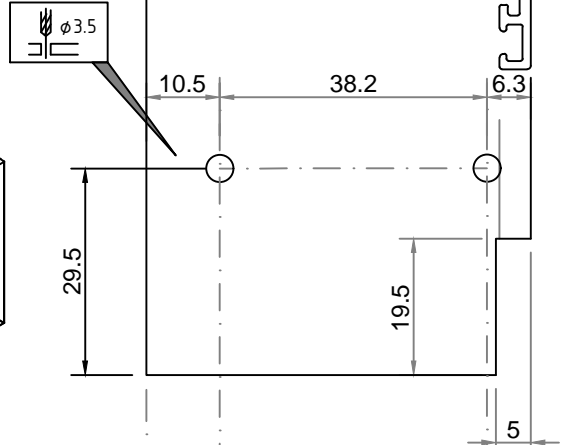
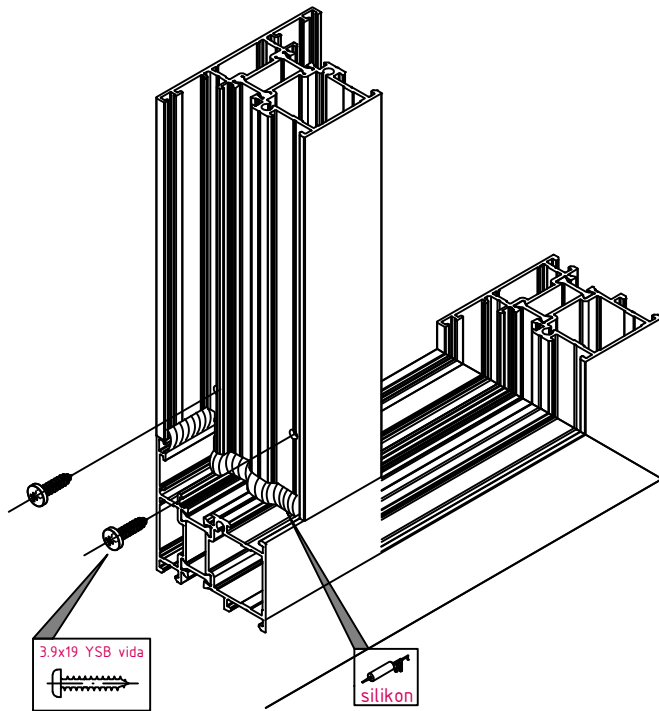

**ALTERNATİF 3**  
ALTERNATIVE 3

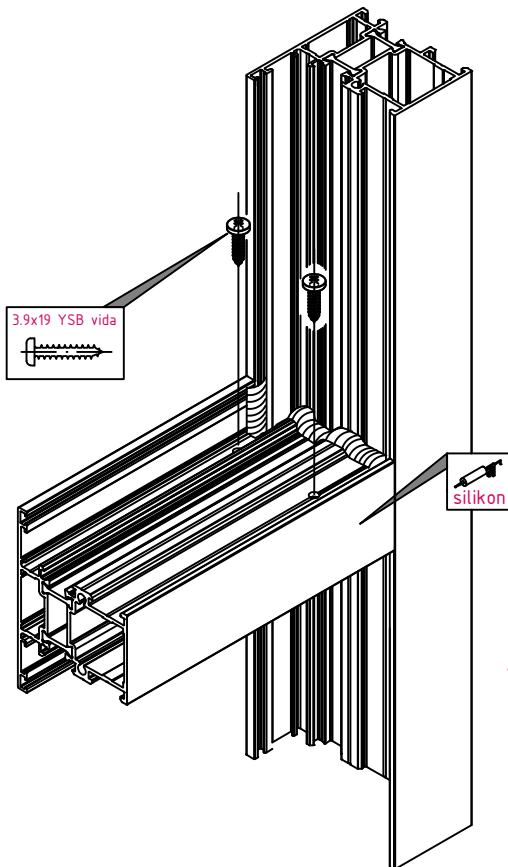

**ALTERNATİF 1**  
ALTERNATIVE 1

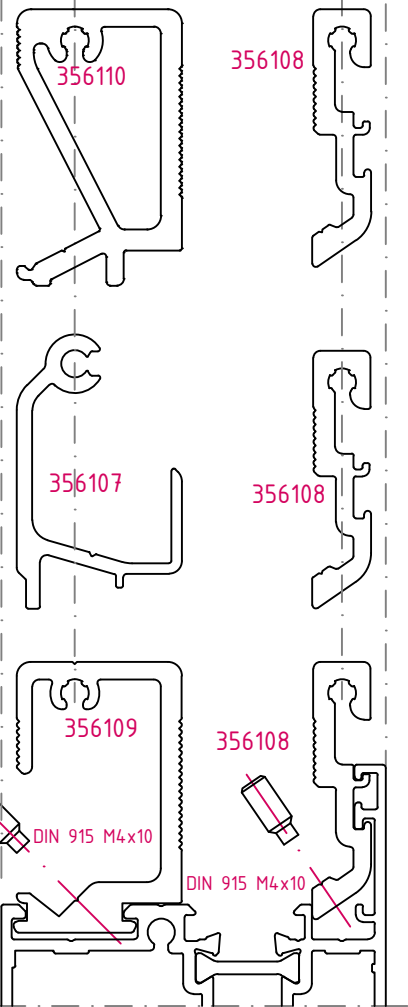

**ALTERNATİF 2**  
ALTERNATIVE 2

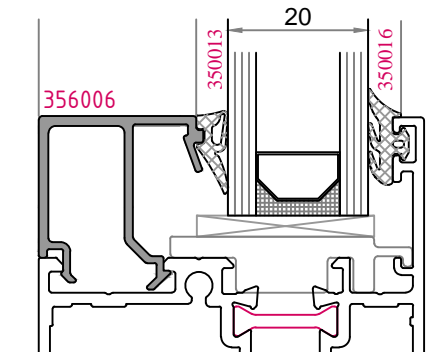
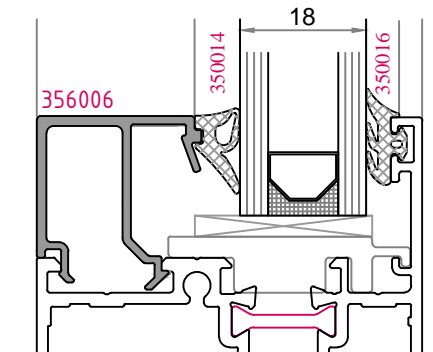
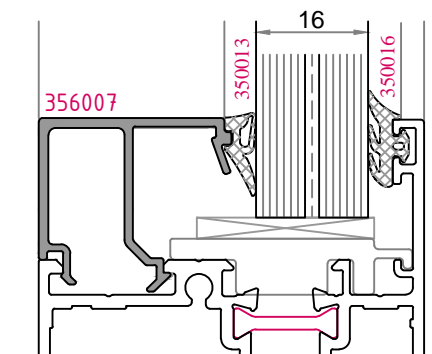
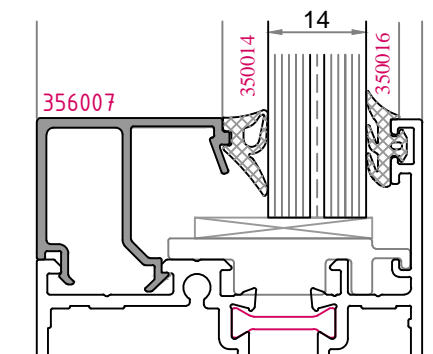
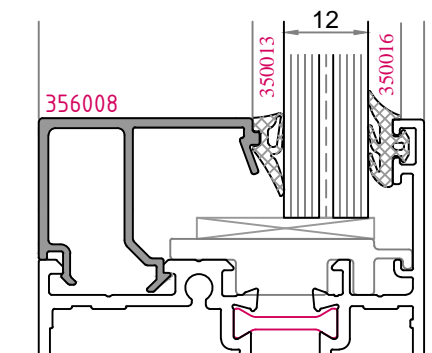
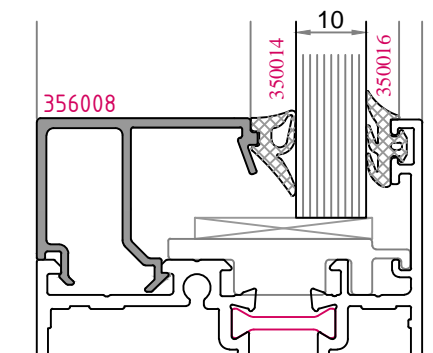
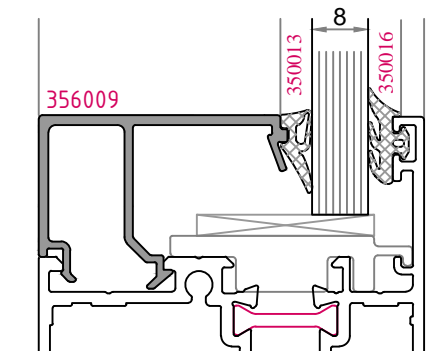
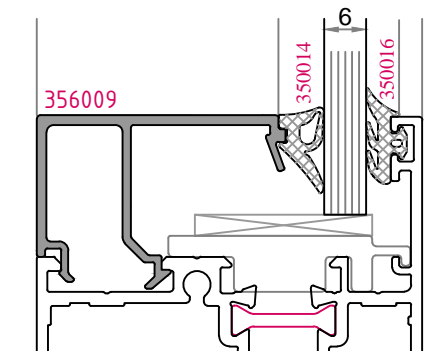
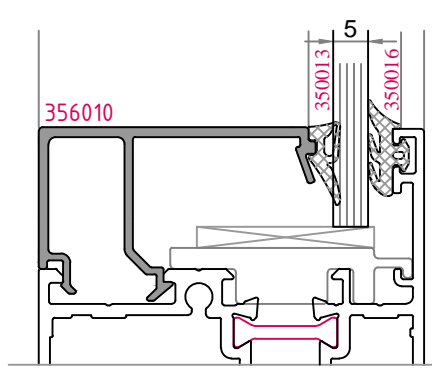
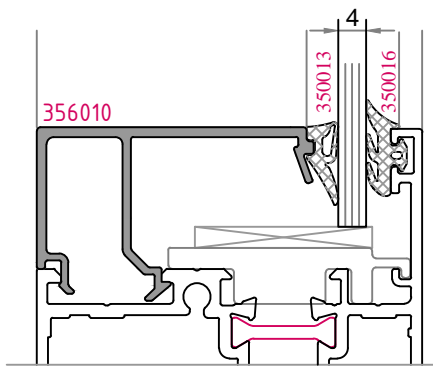



# IQ-2150 FORMO

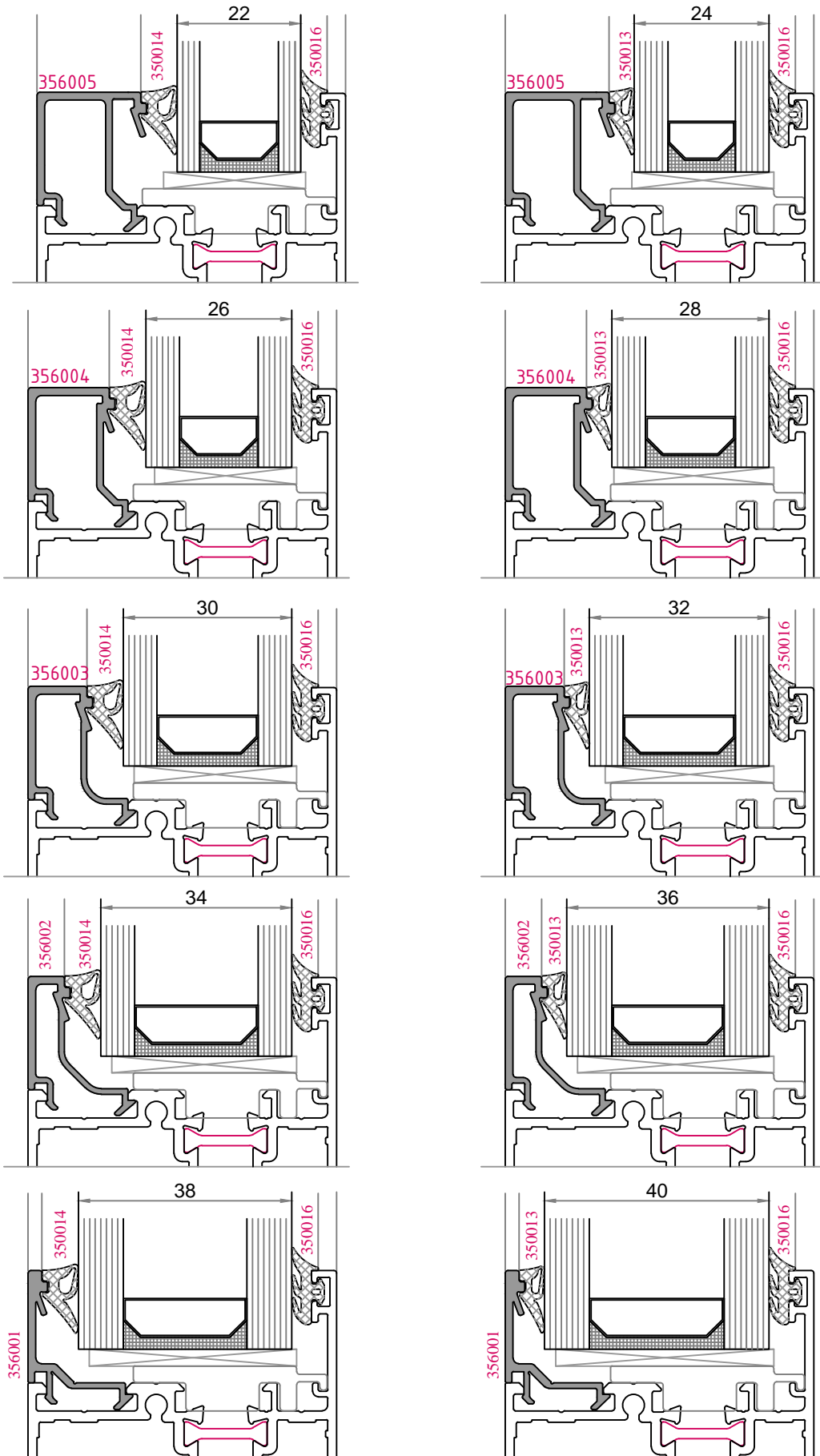

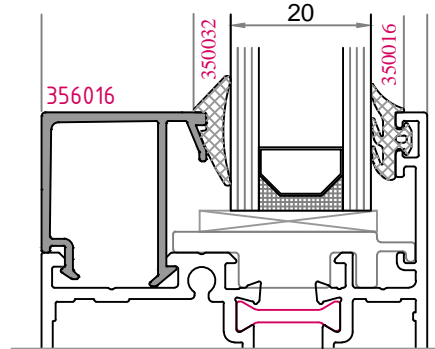
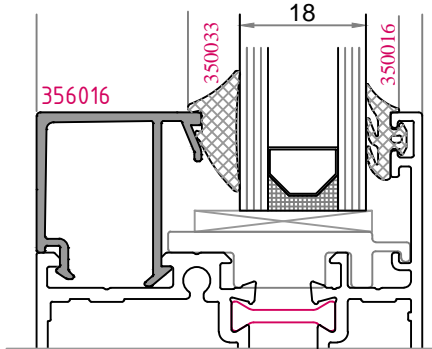
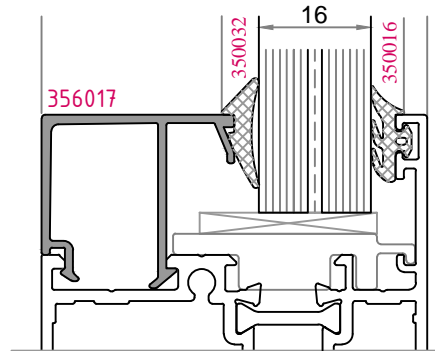
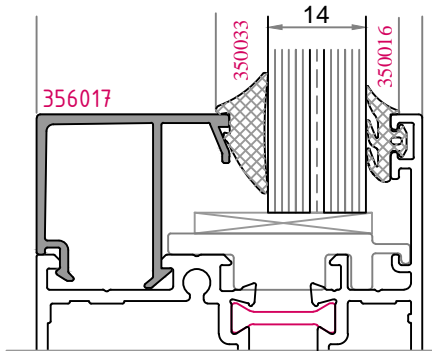
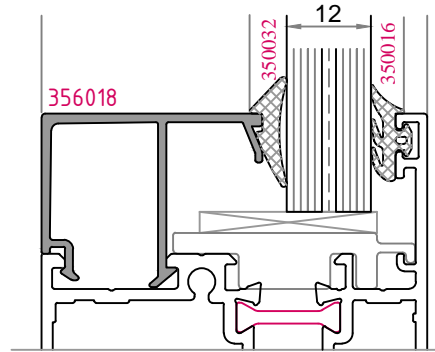
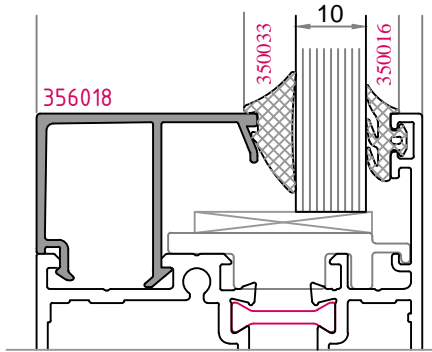
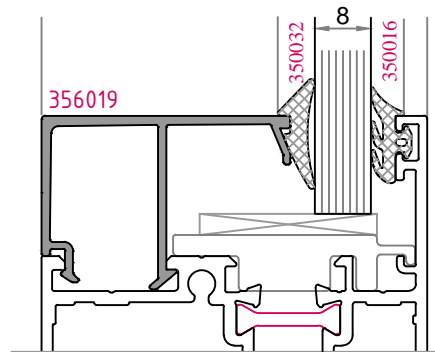
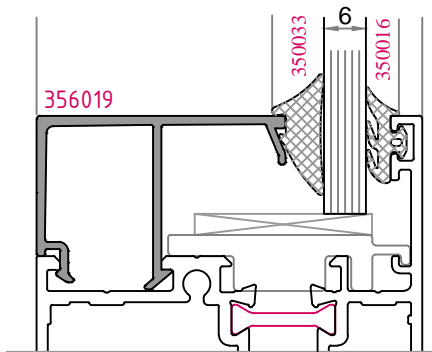
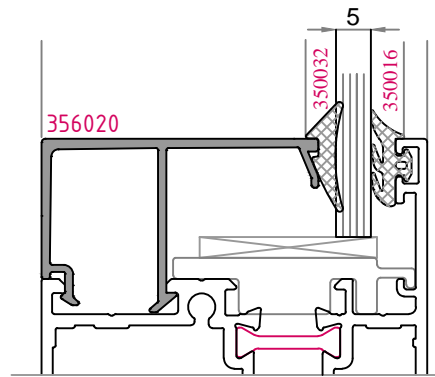
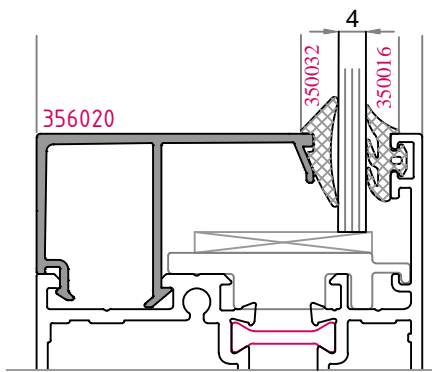

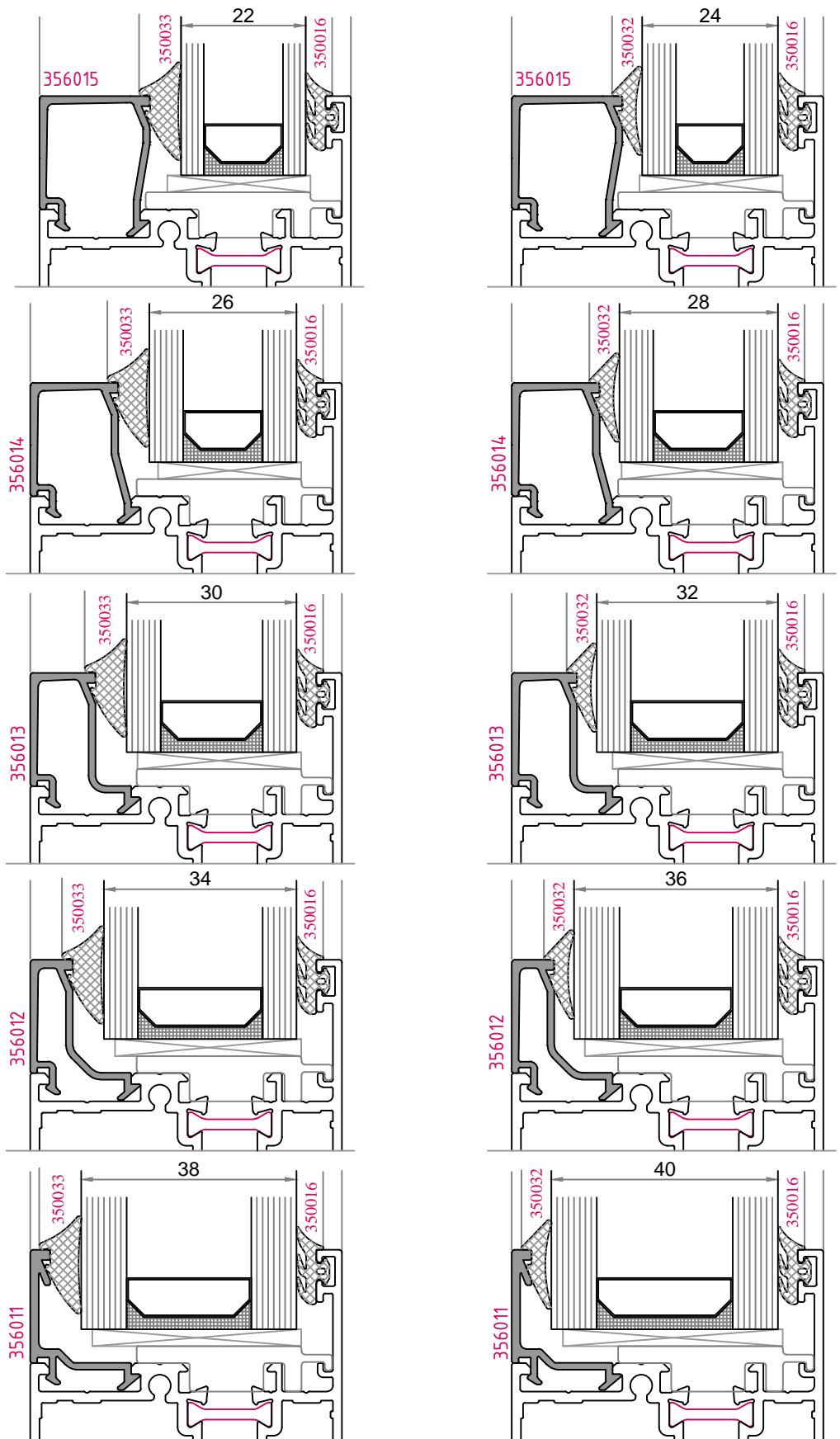

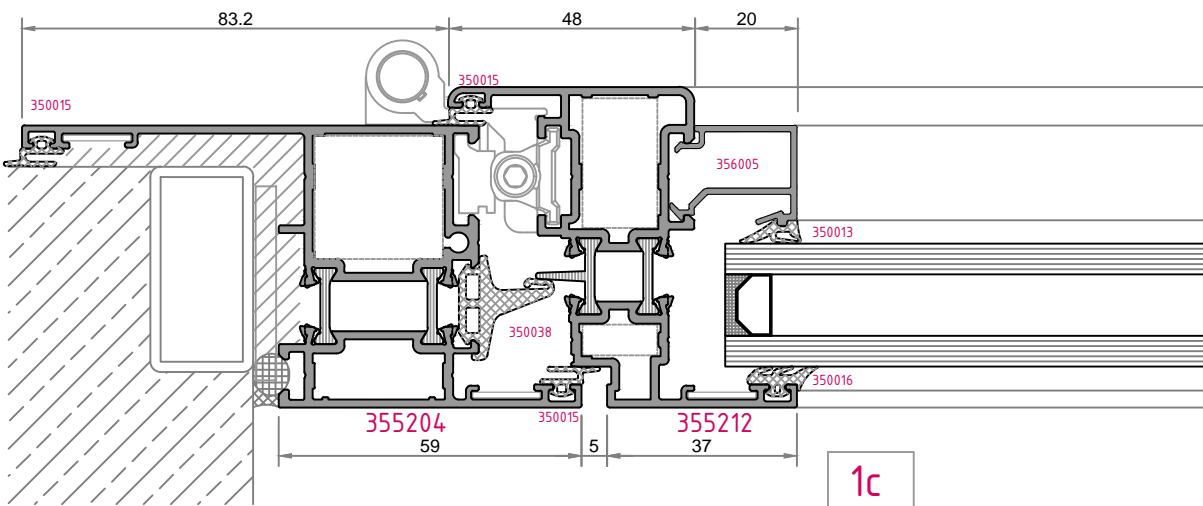
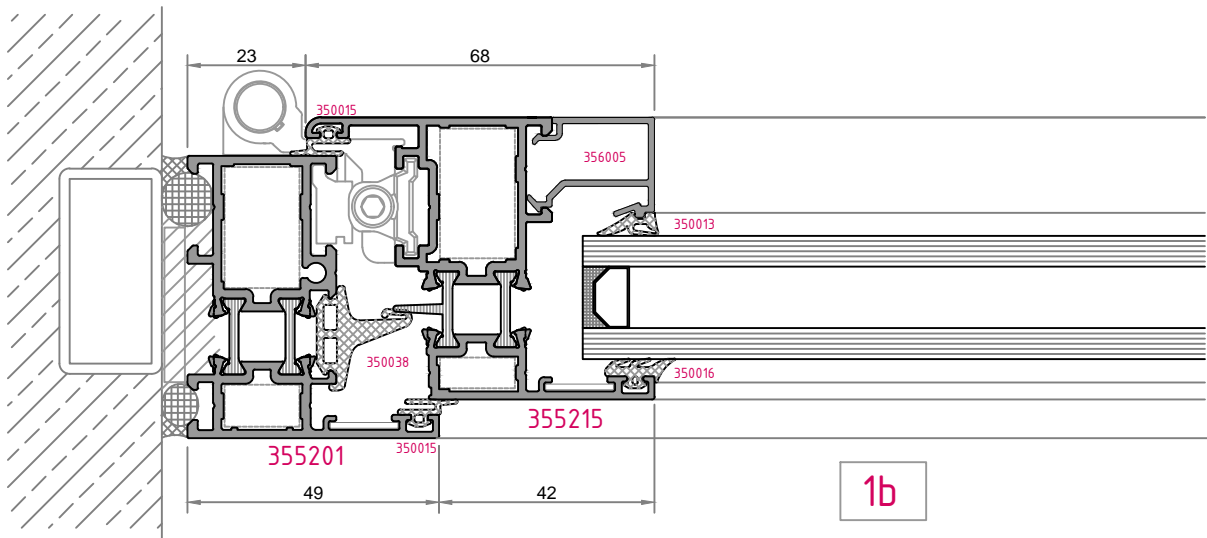
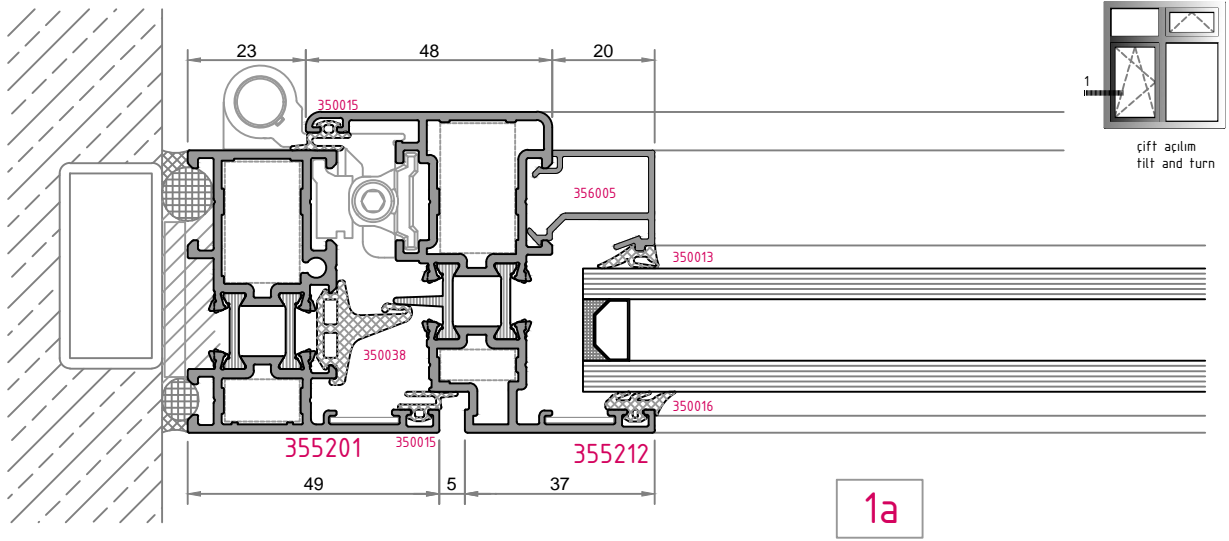

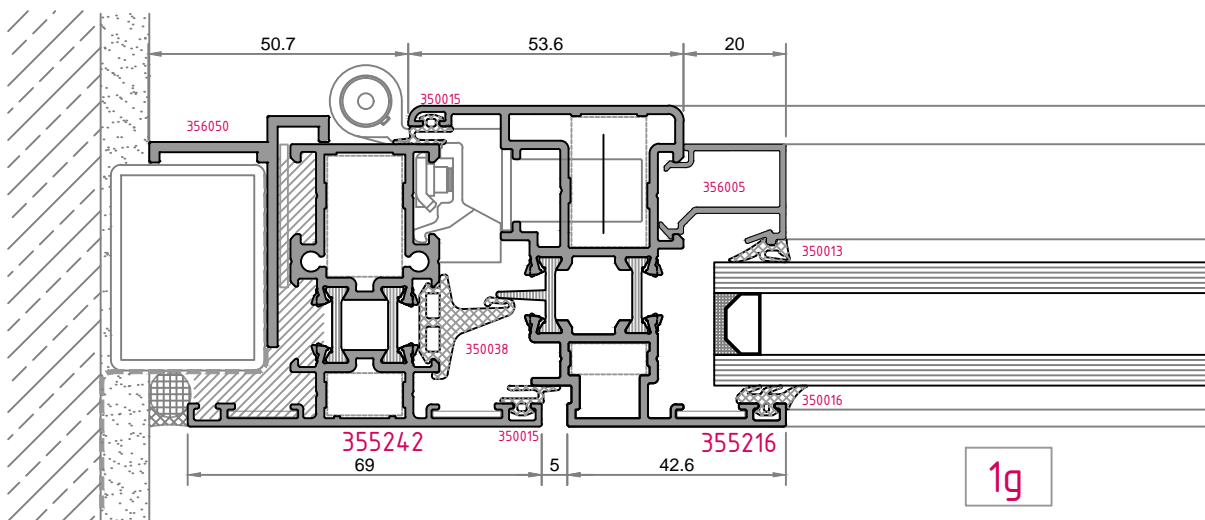
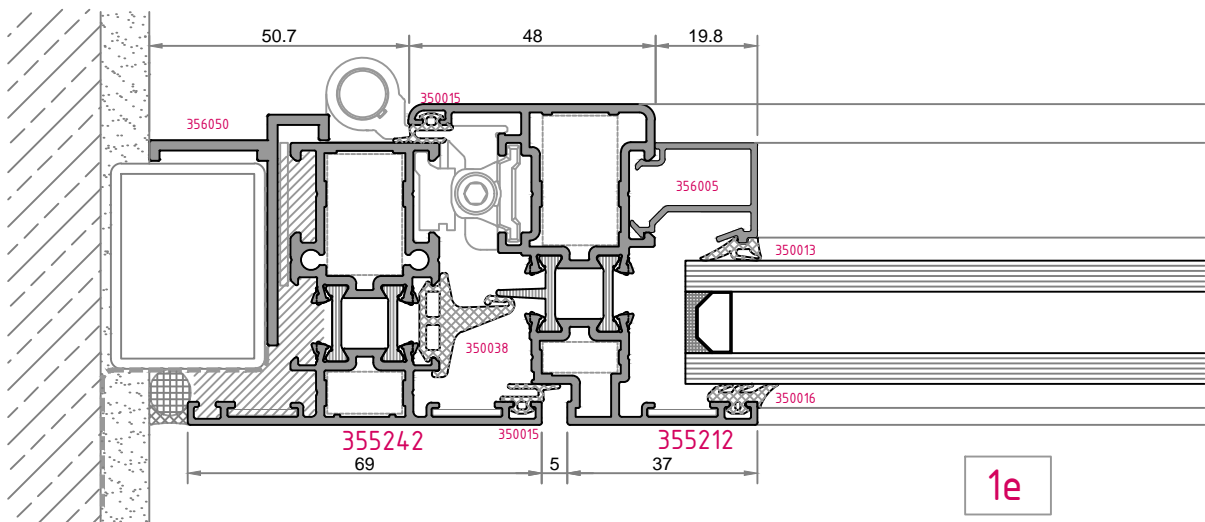
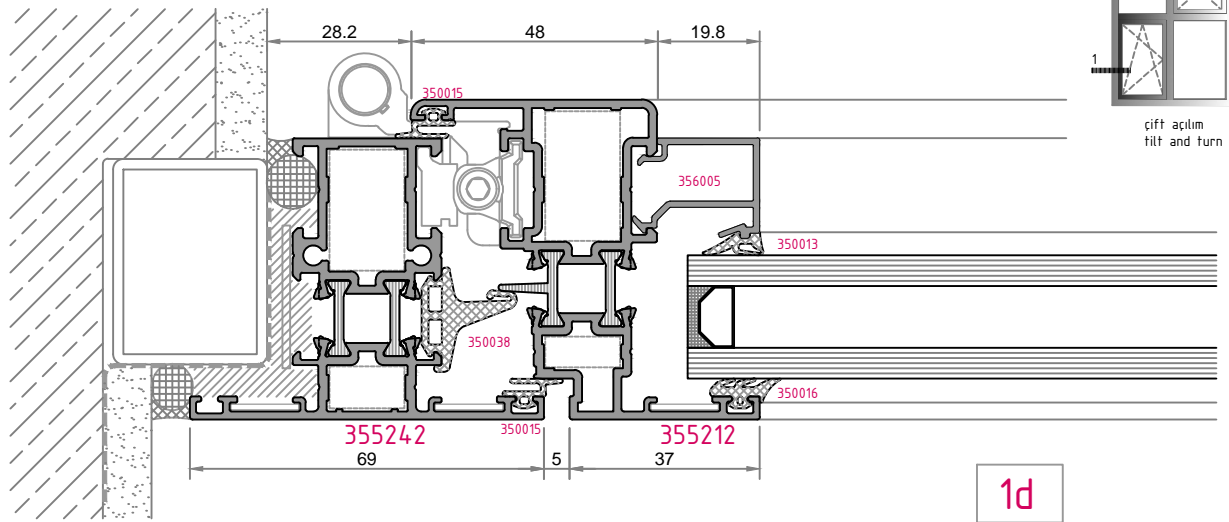

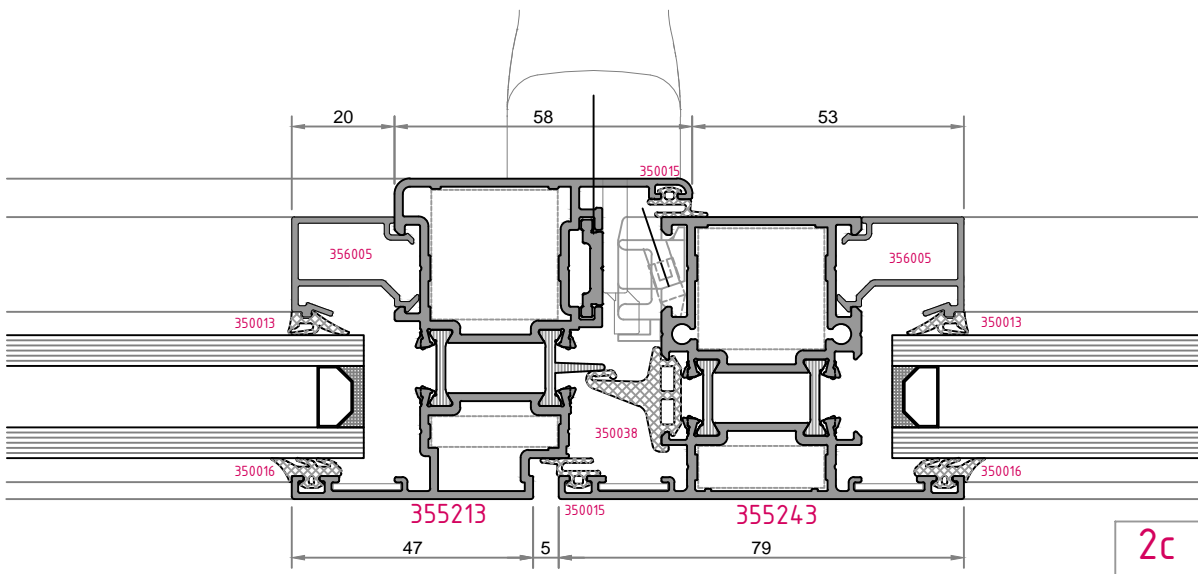
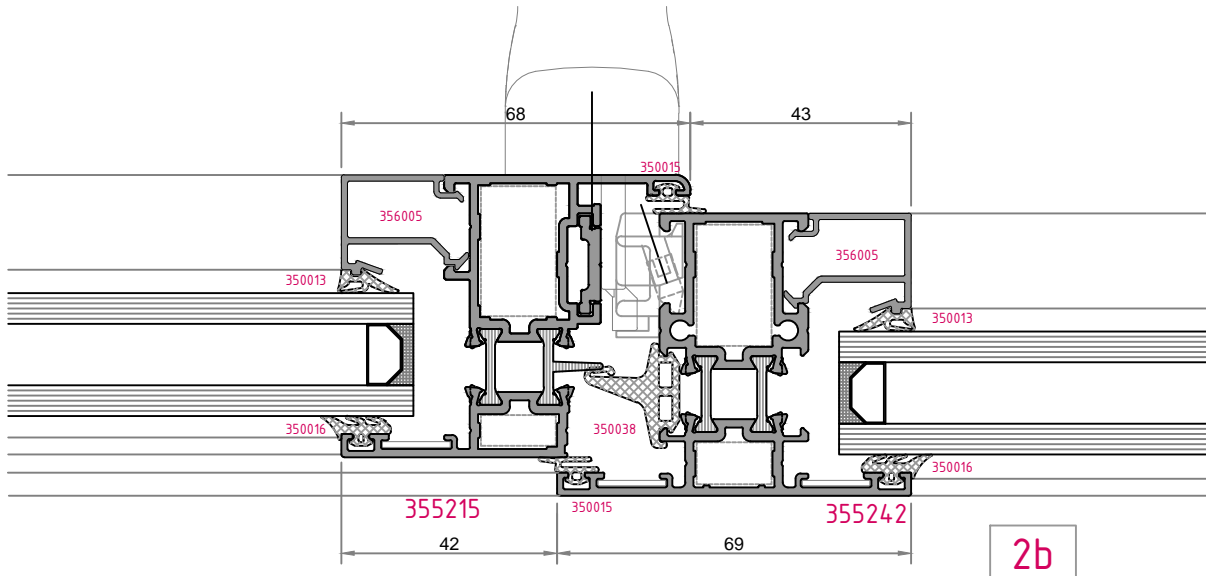
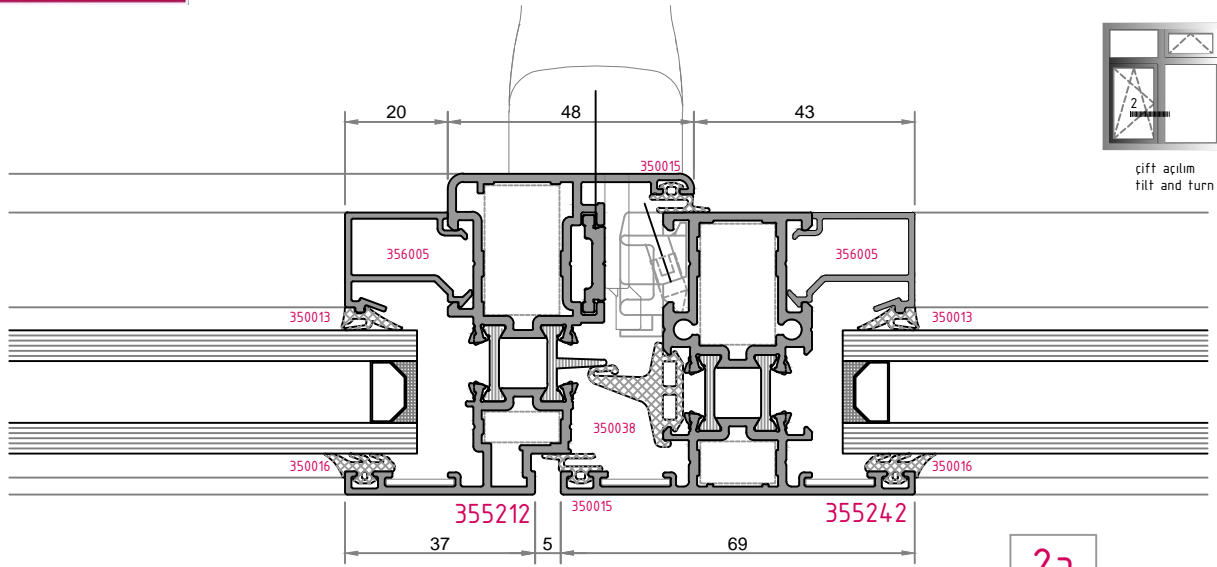

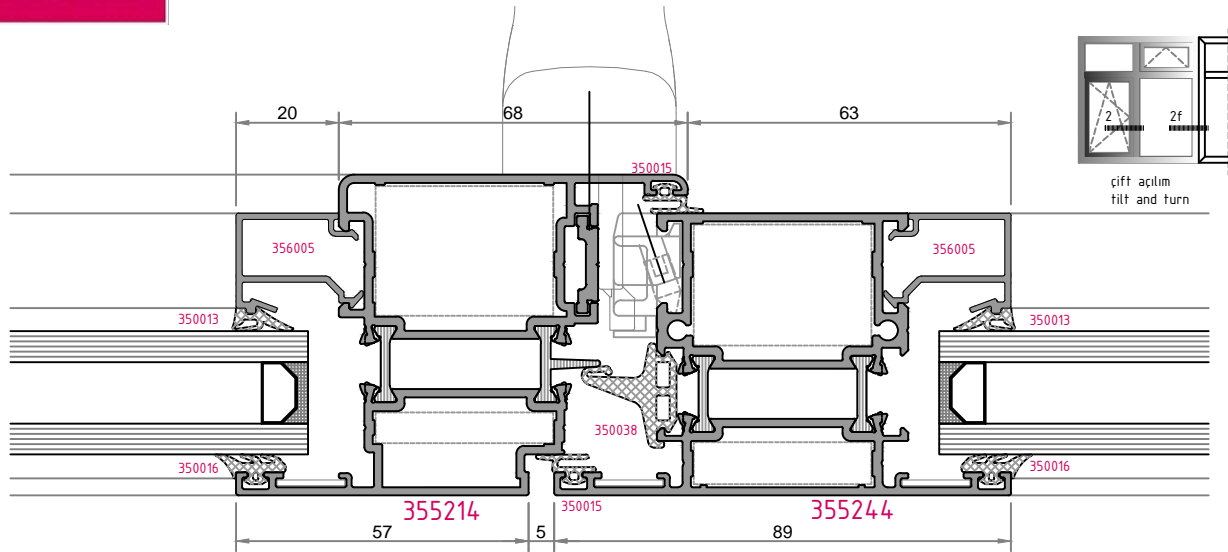

2d

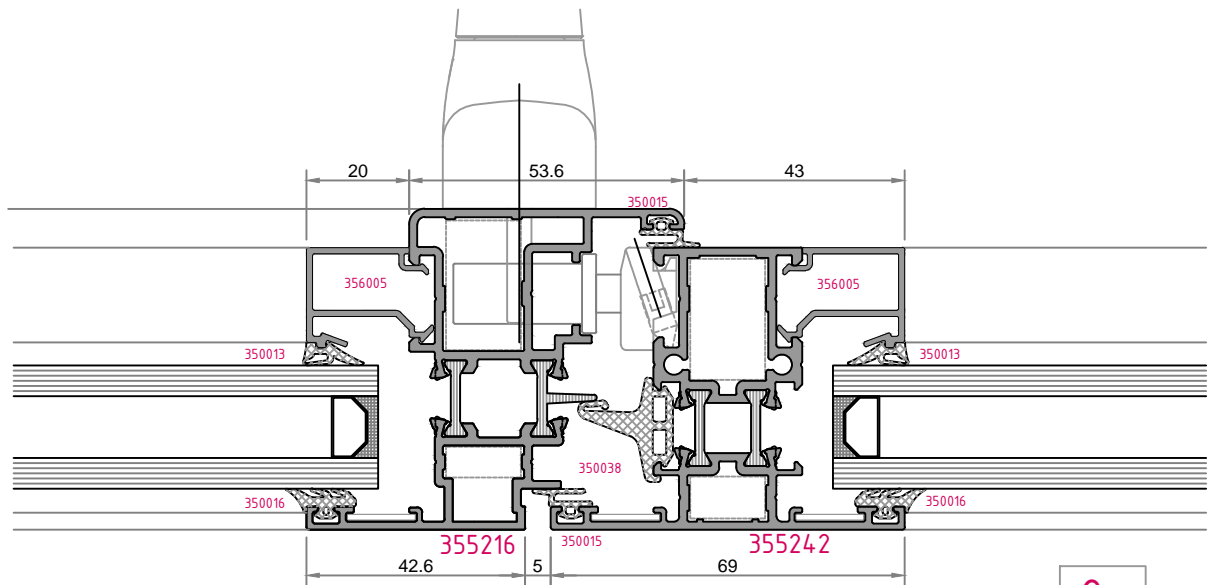

2e

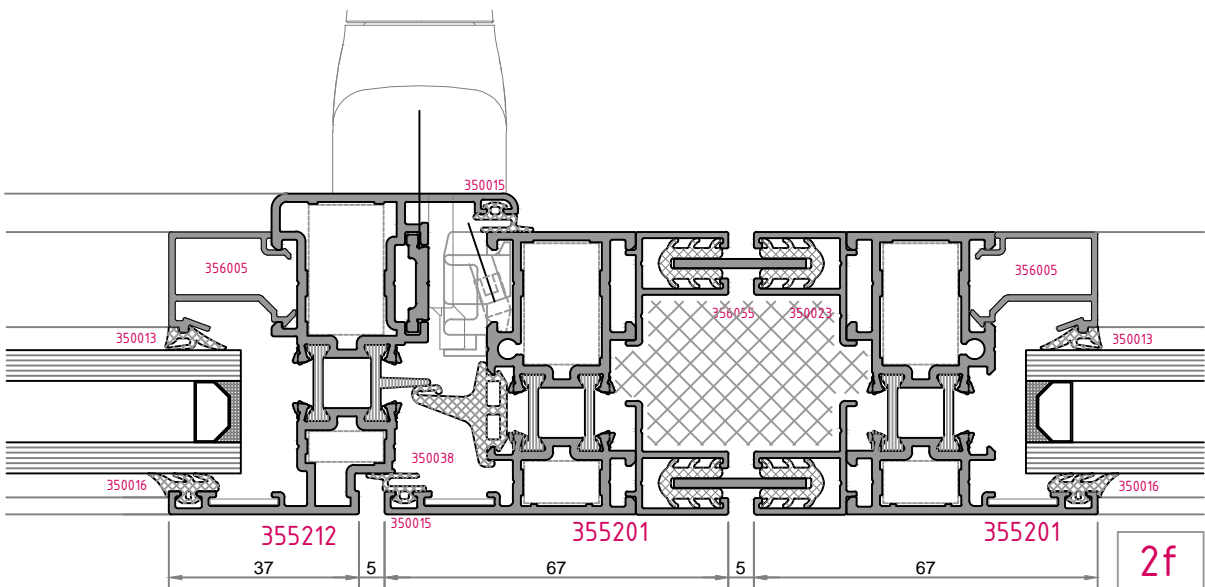

2f

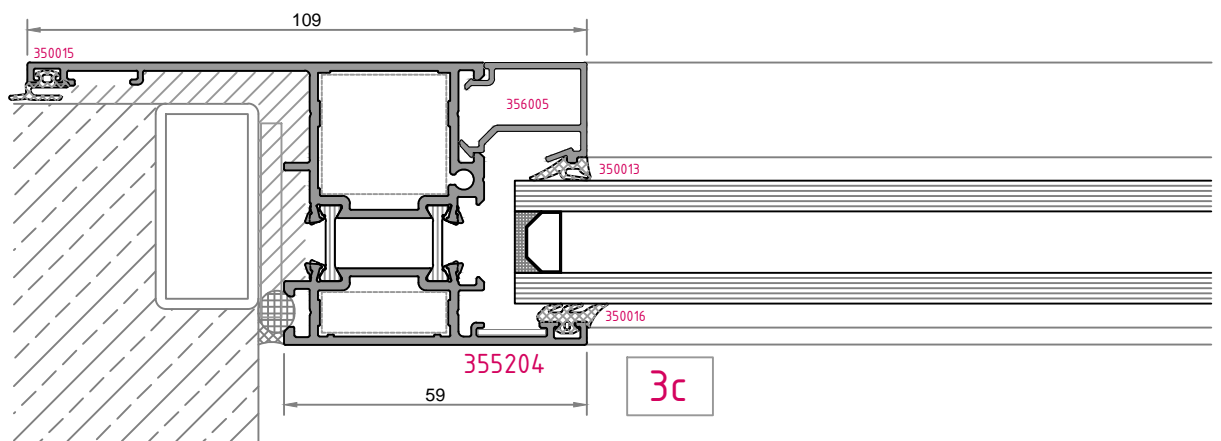
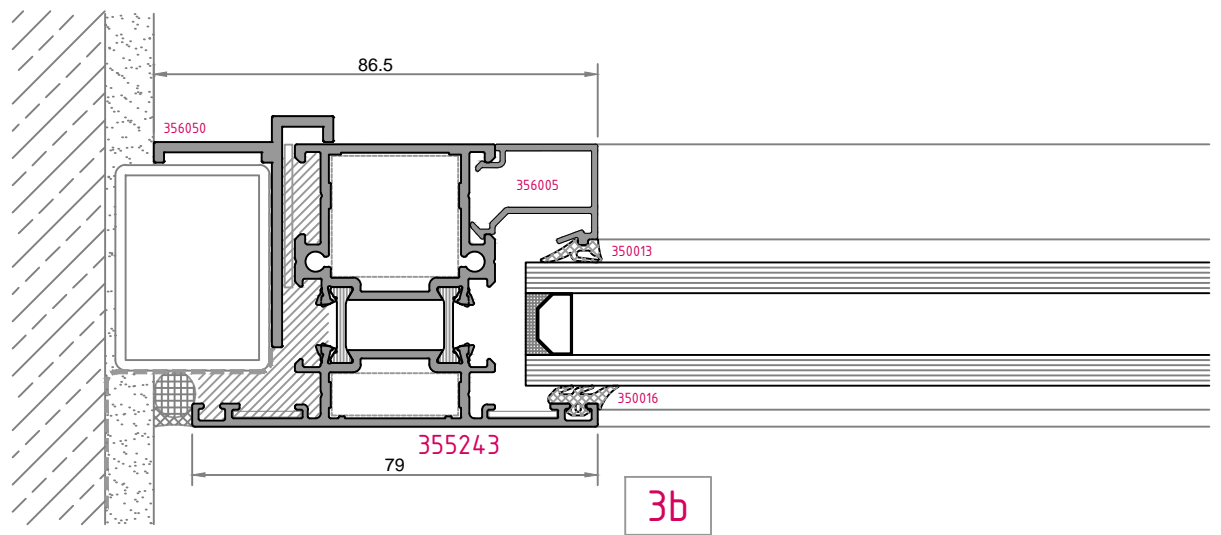
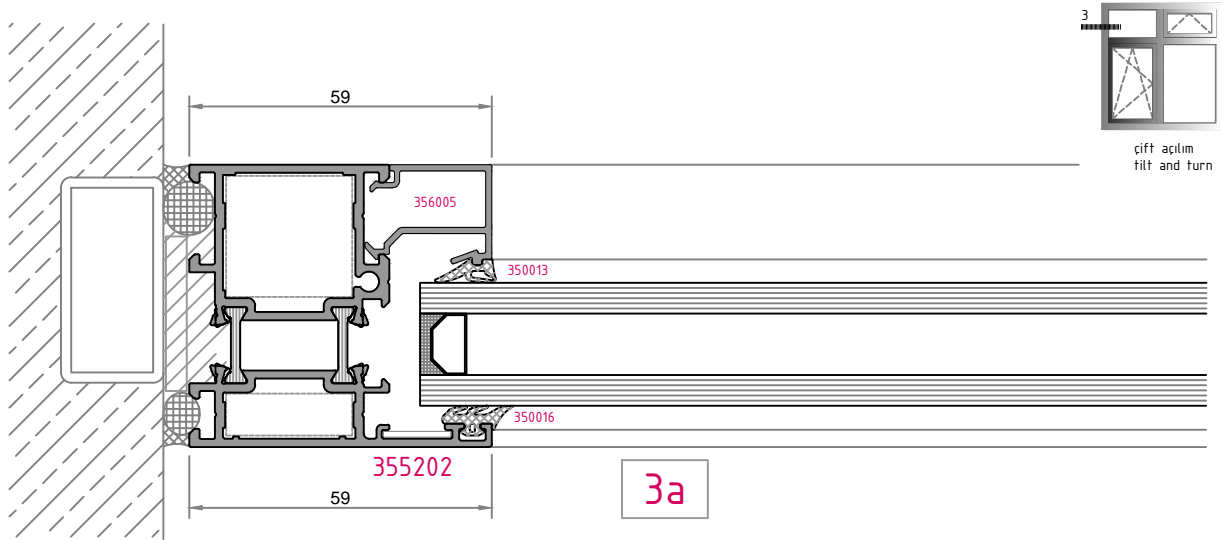



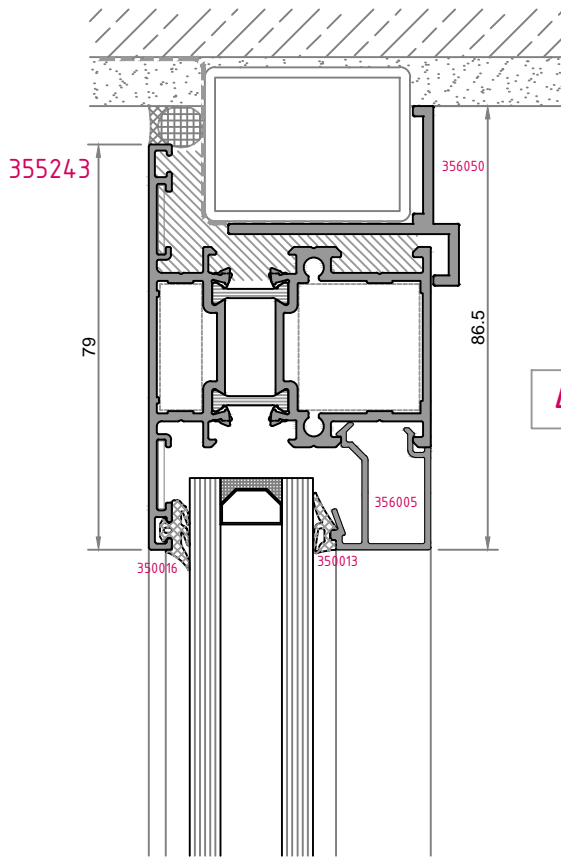

4a

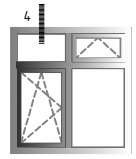

çift açılım  
tilt and turn

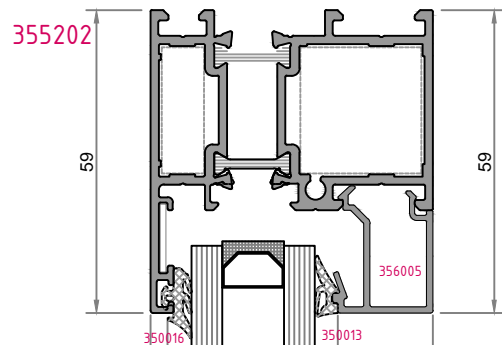

4c

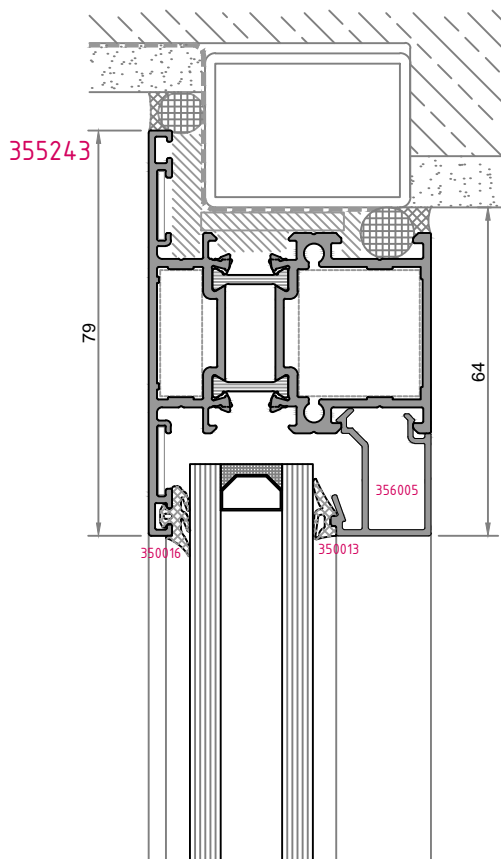

4b

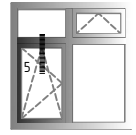

gitt açılım  
filt and turn

**5a**

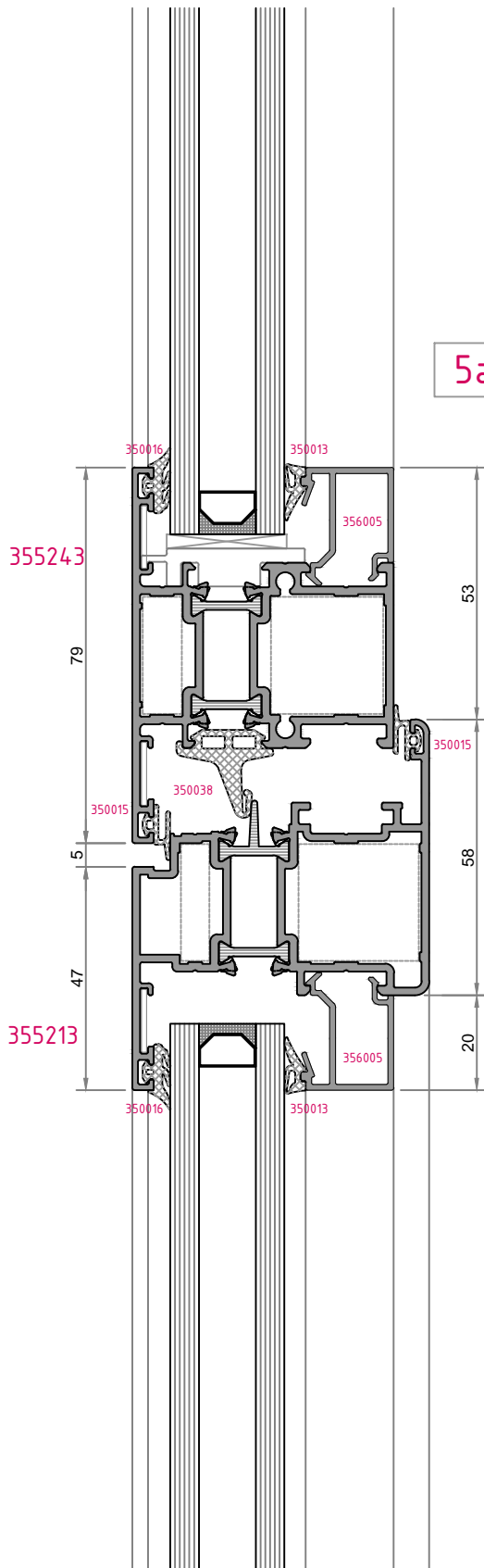

**5b**

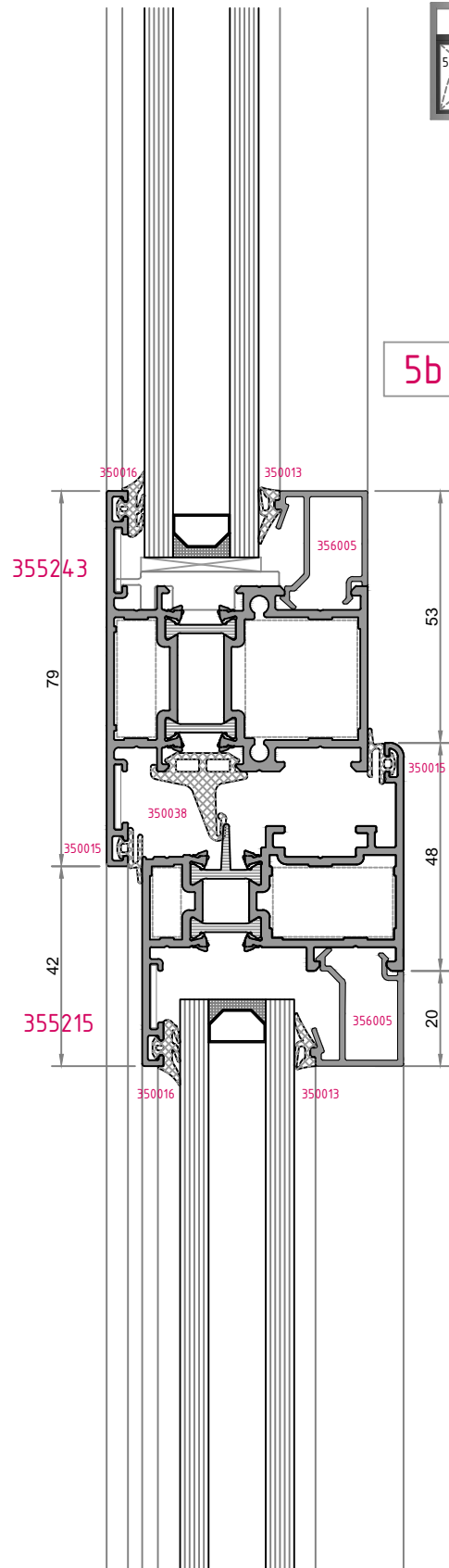

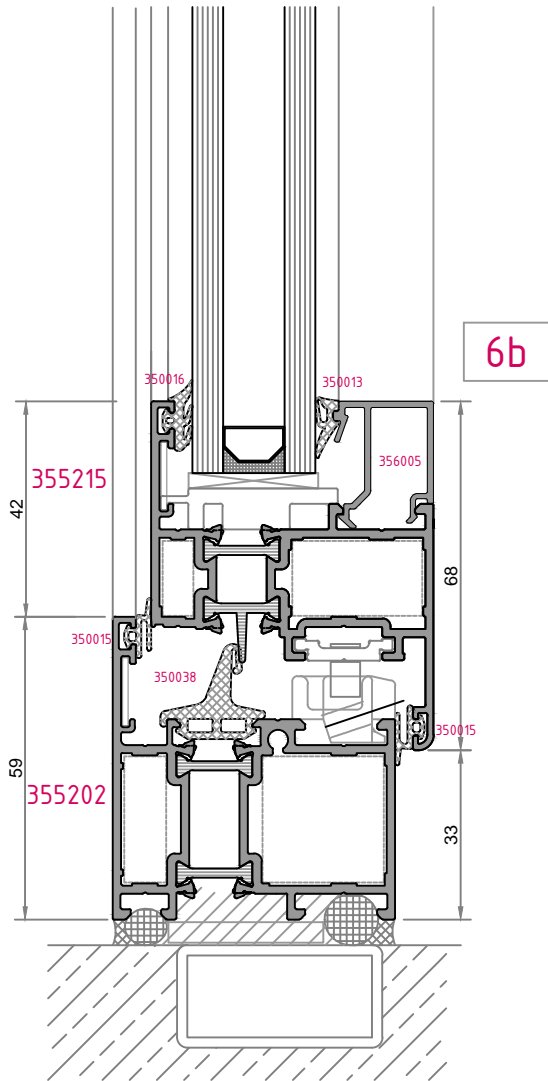

**6a**

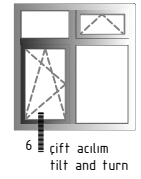
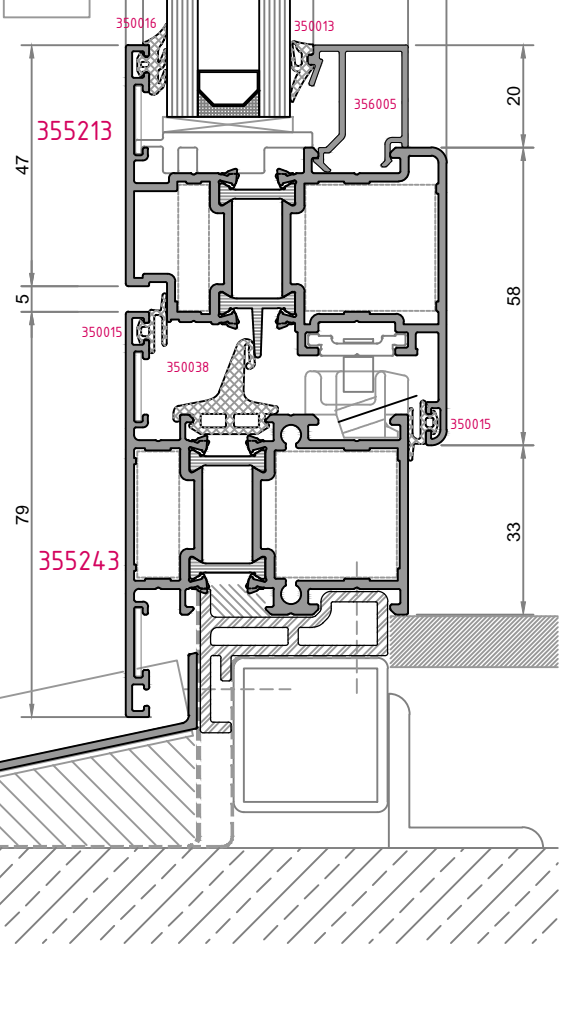

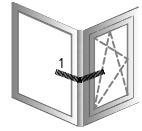

köşe dönüş  
corner turn

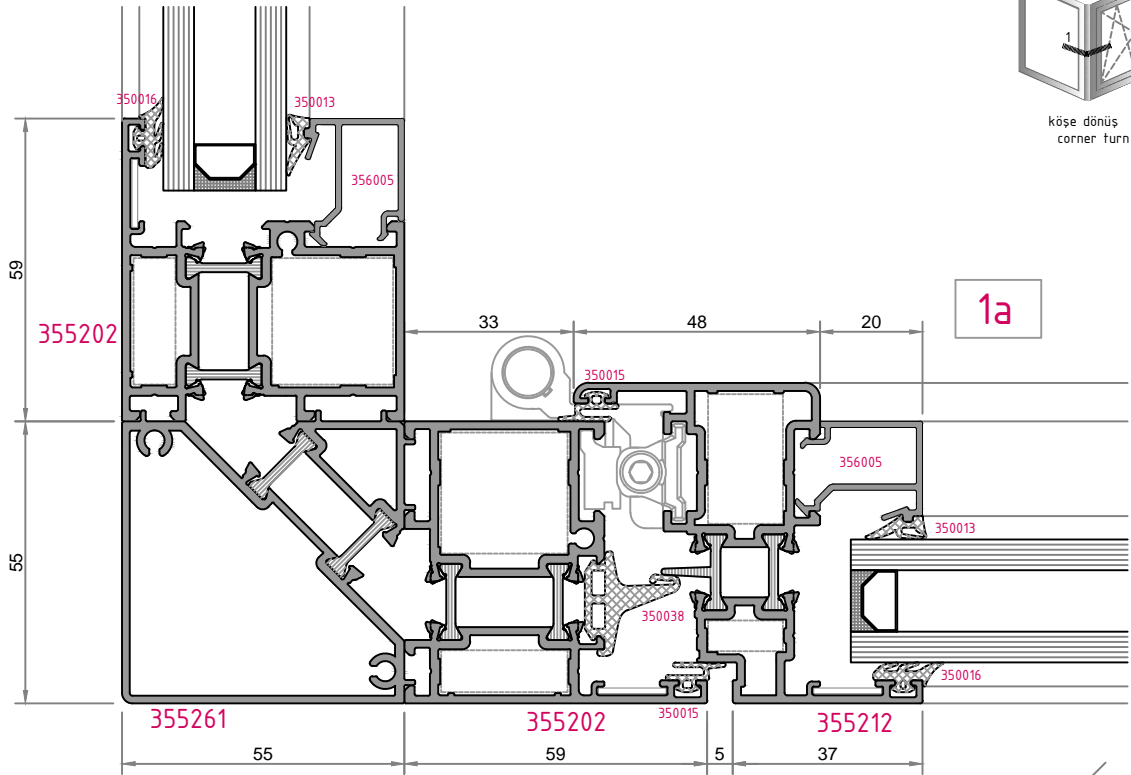

1a

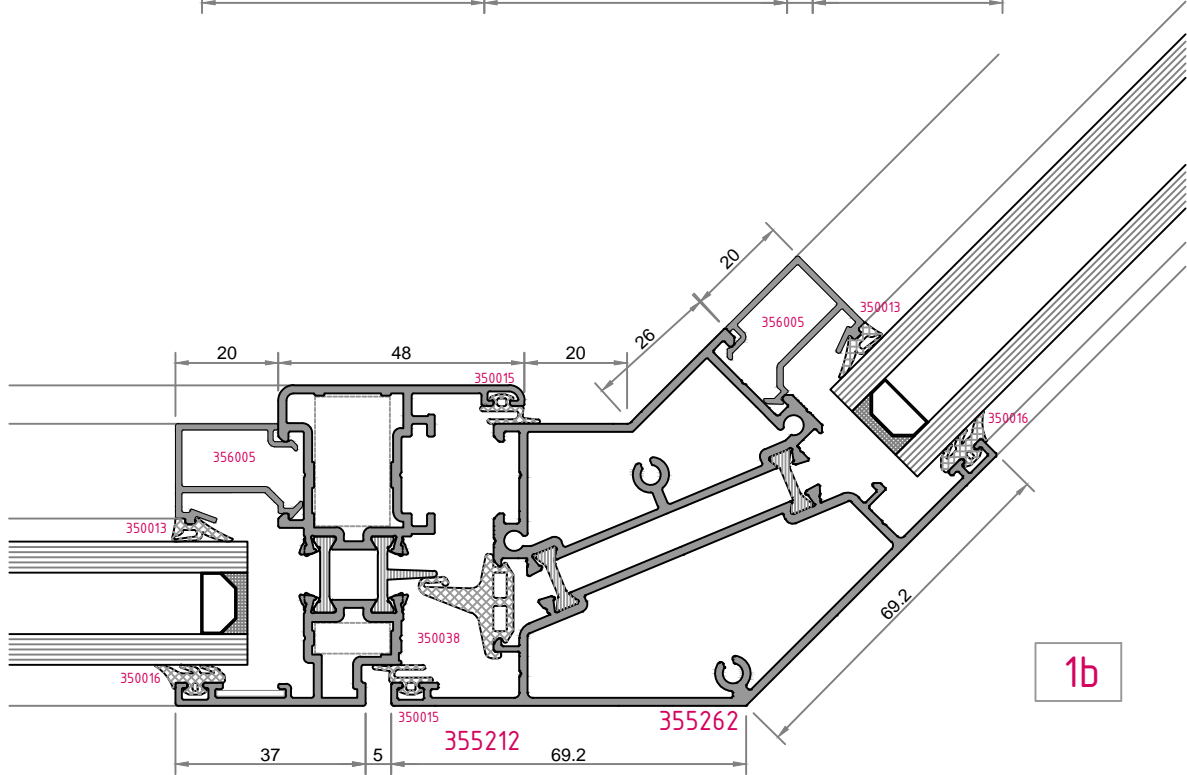

1b

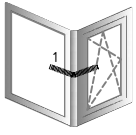

köşe dönüs  
corner turn

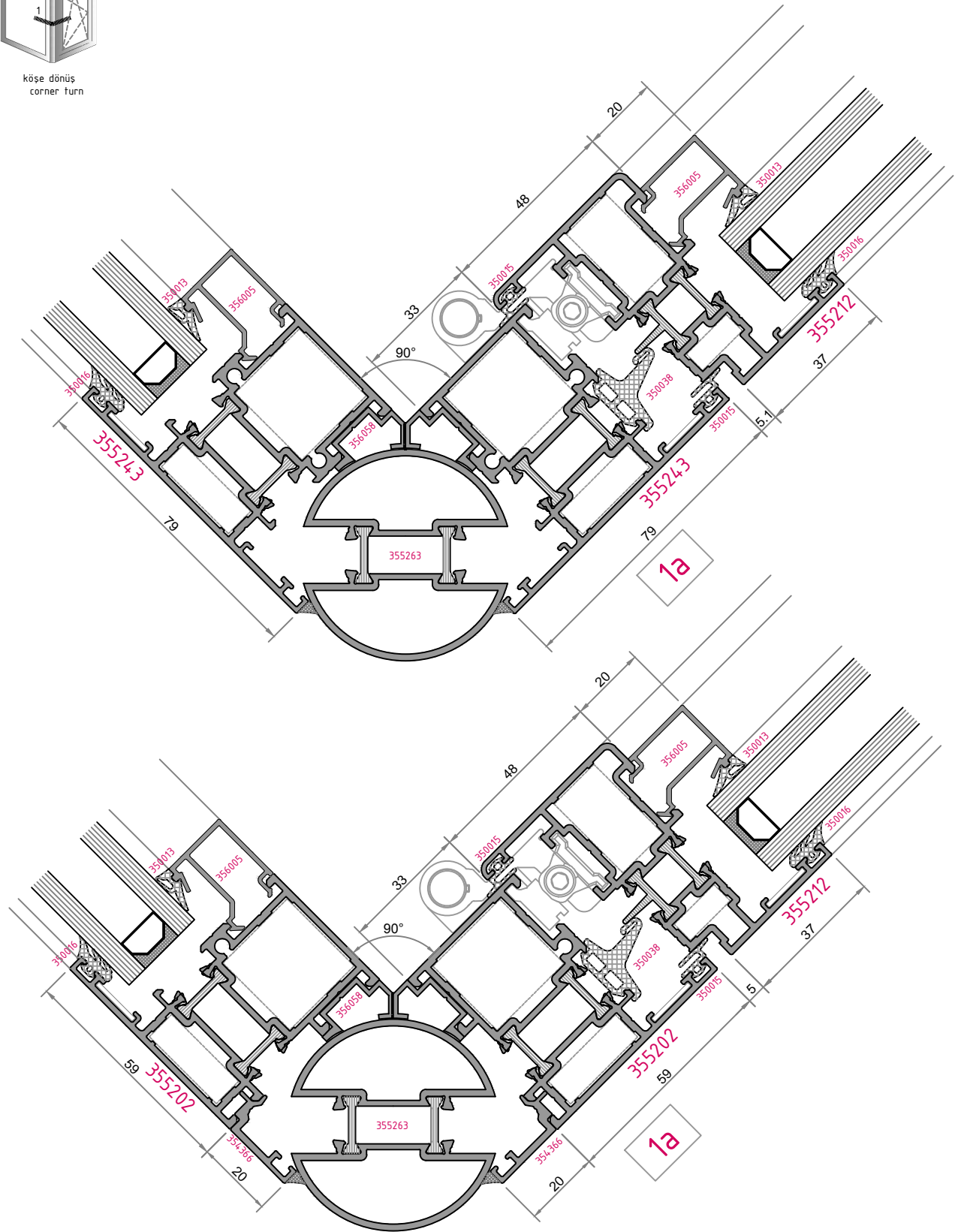



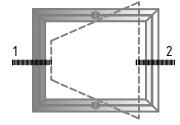

pivot açılım  
pivot opening

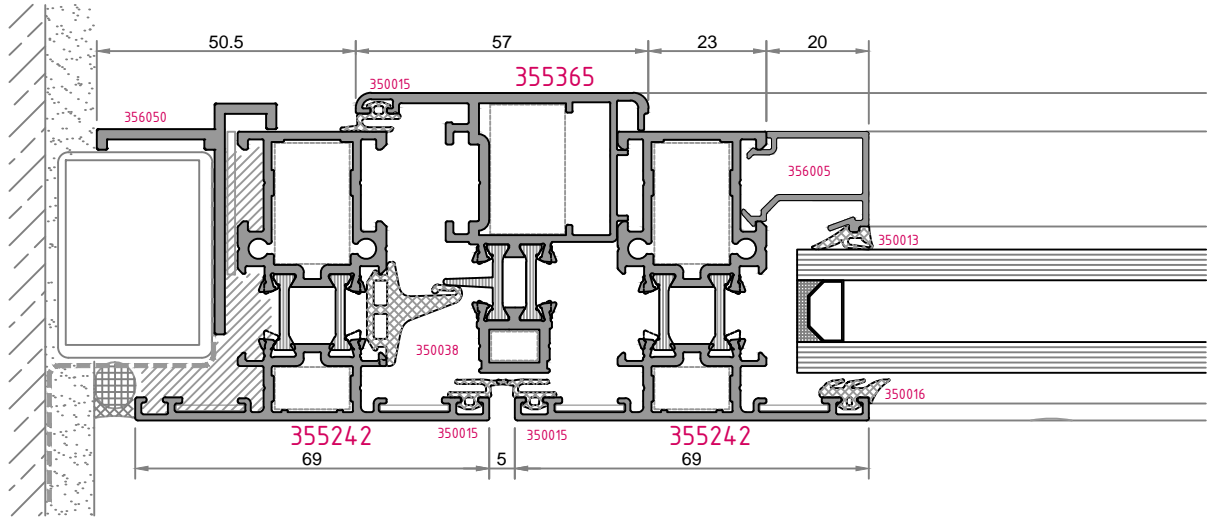

1

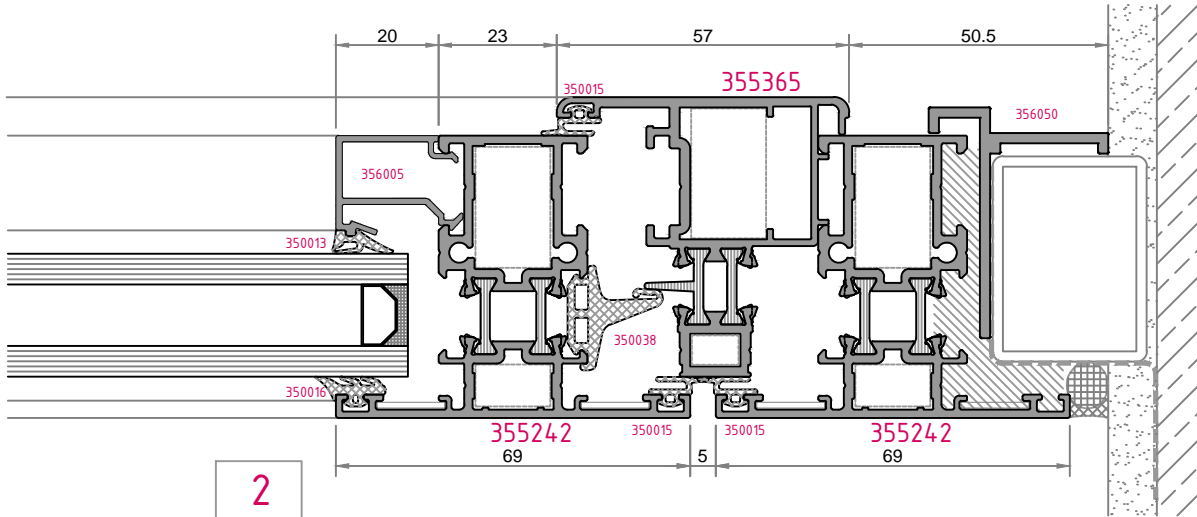

2

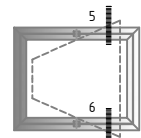

pivot açılım  
pivot opening

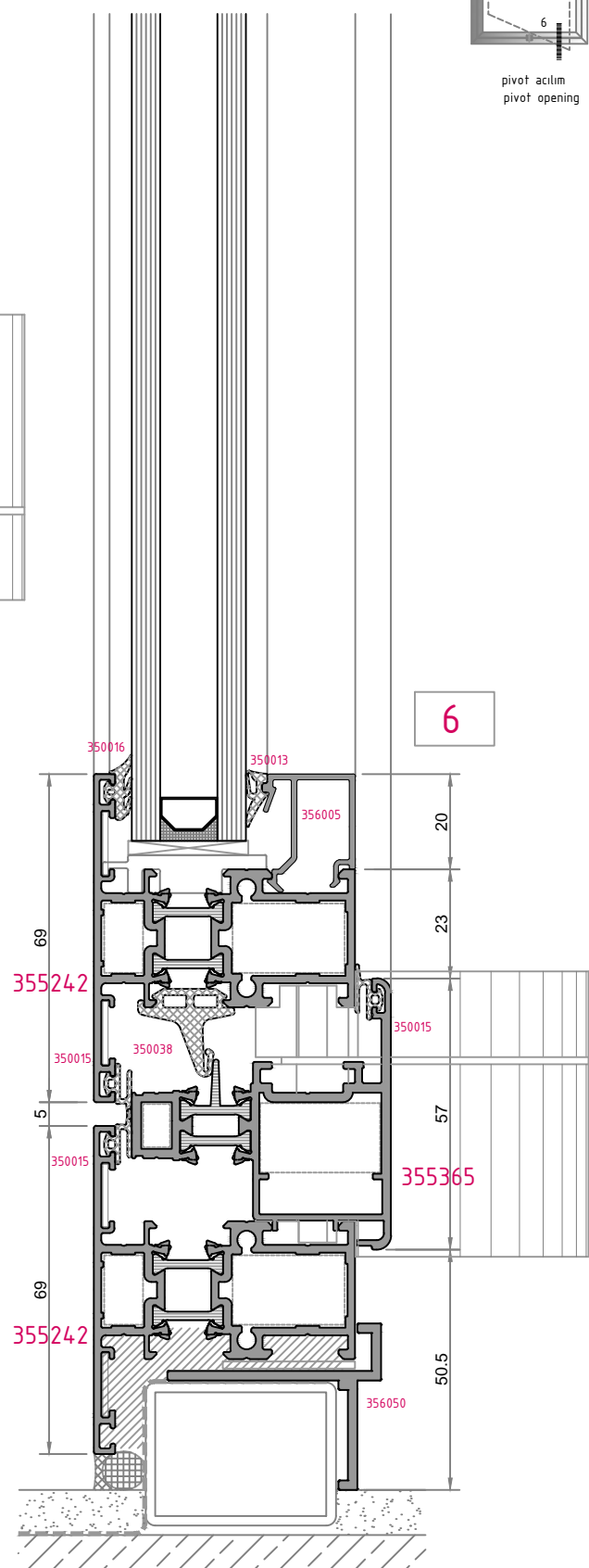
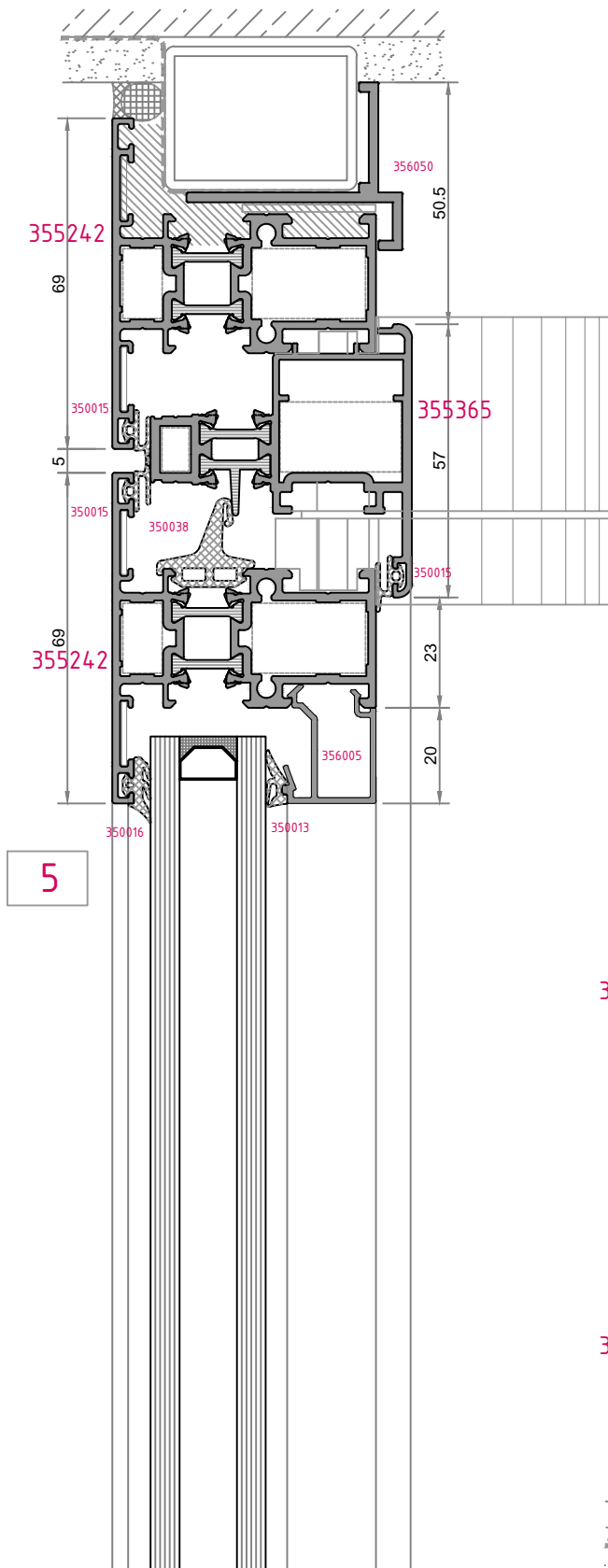



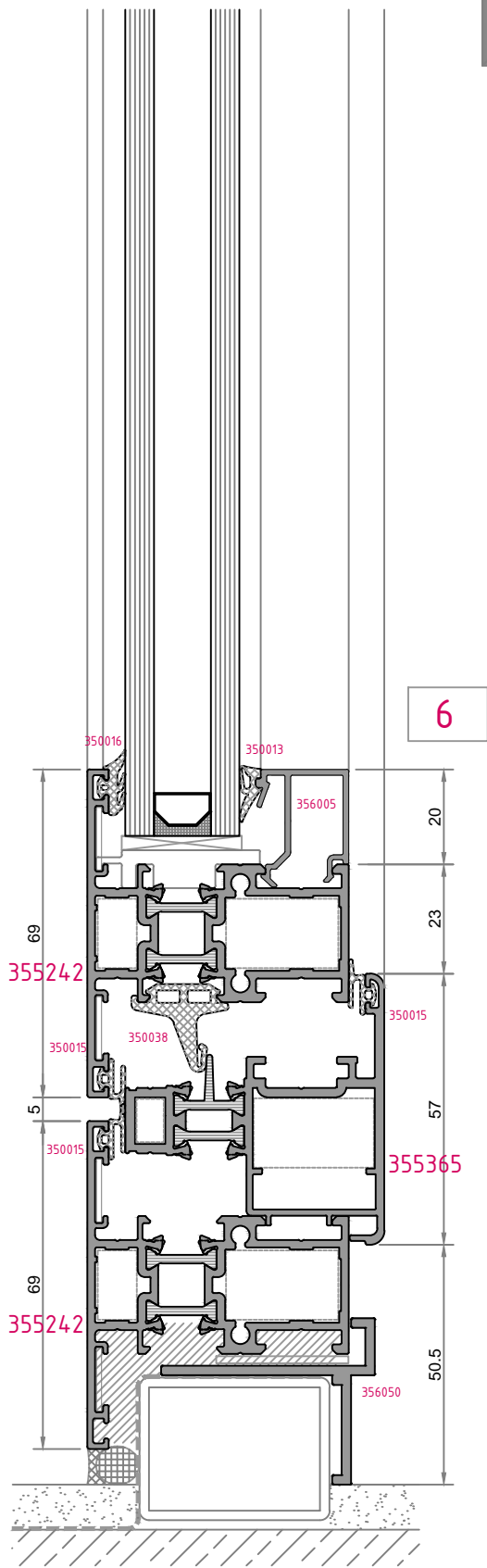
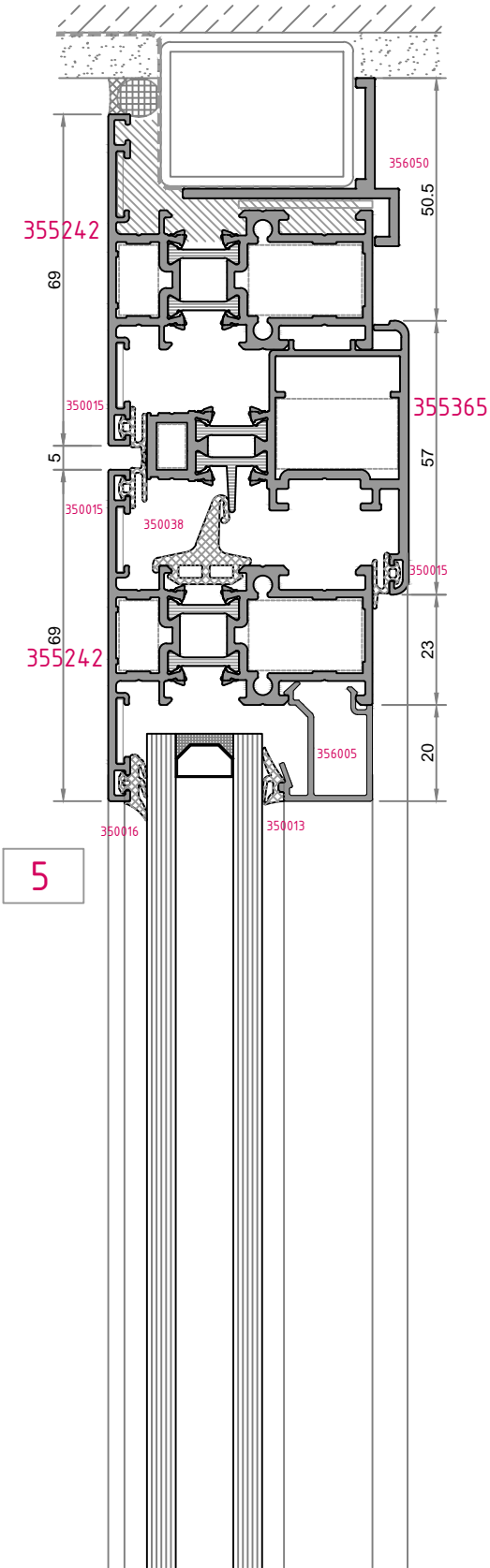
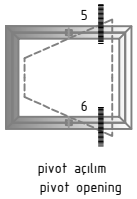

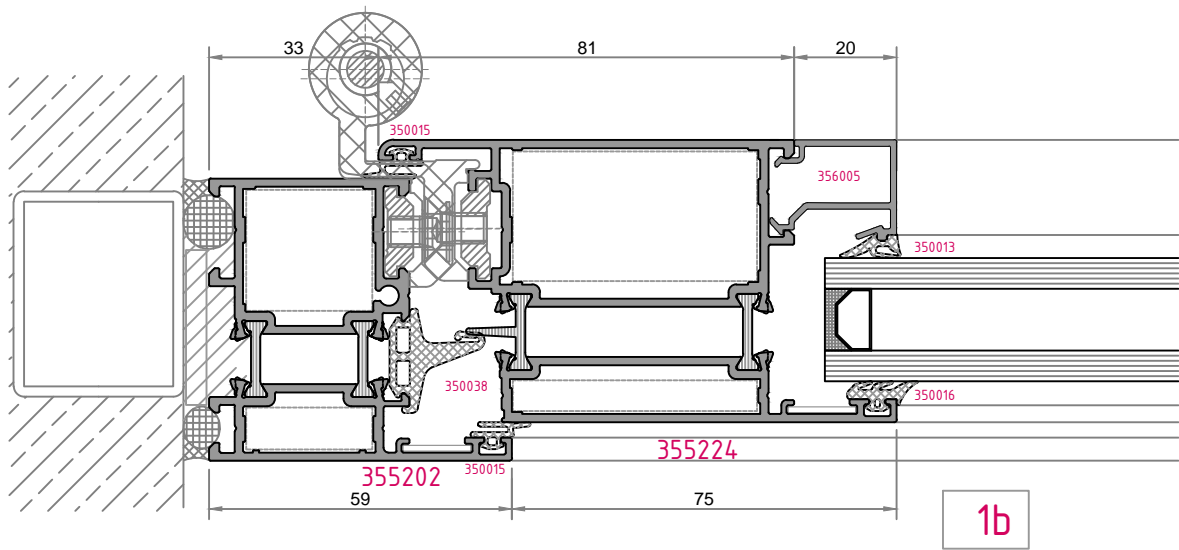
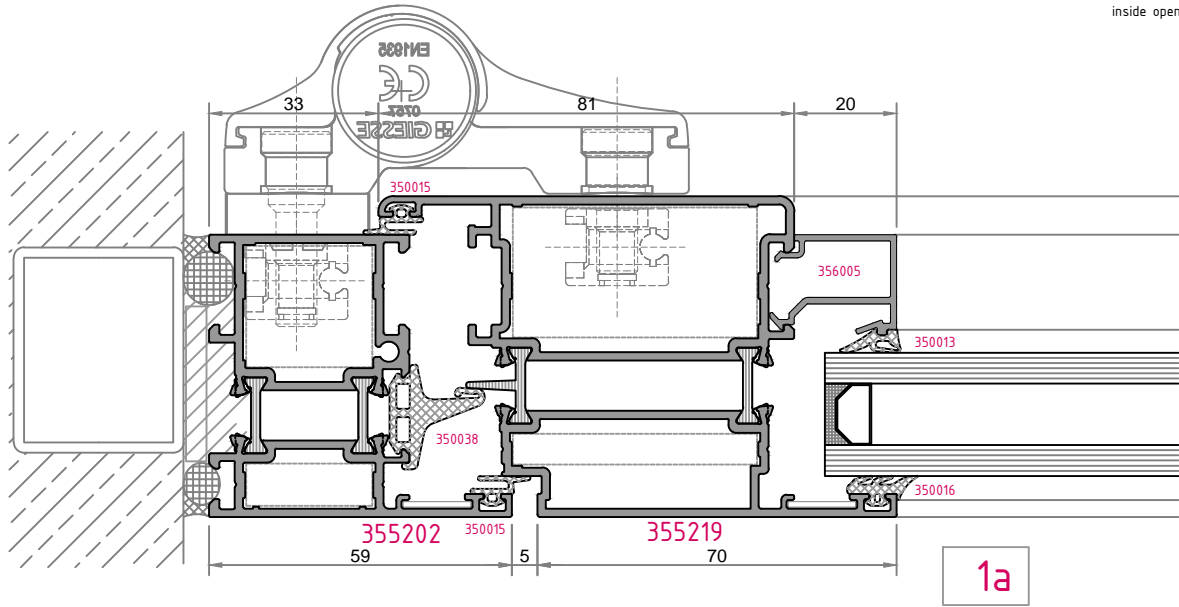
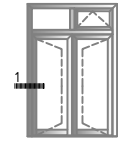

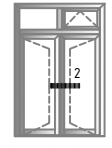

içe açılım kapı  
inside opening door

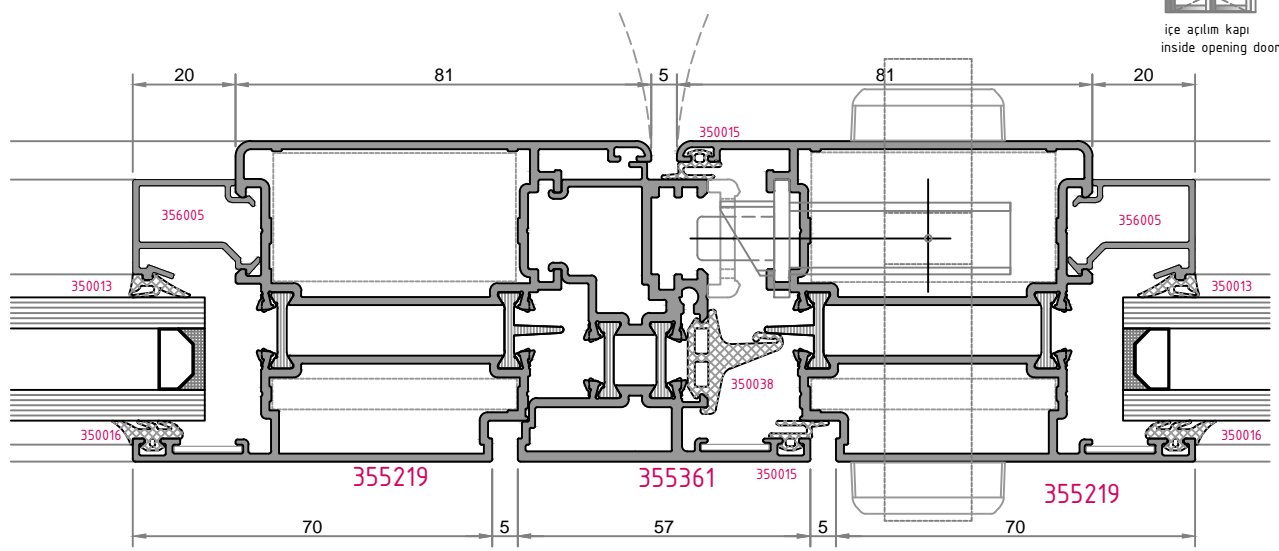

2a

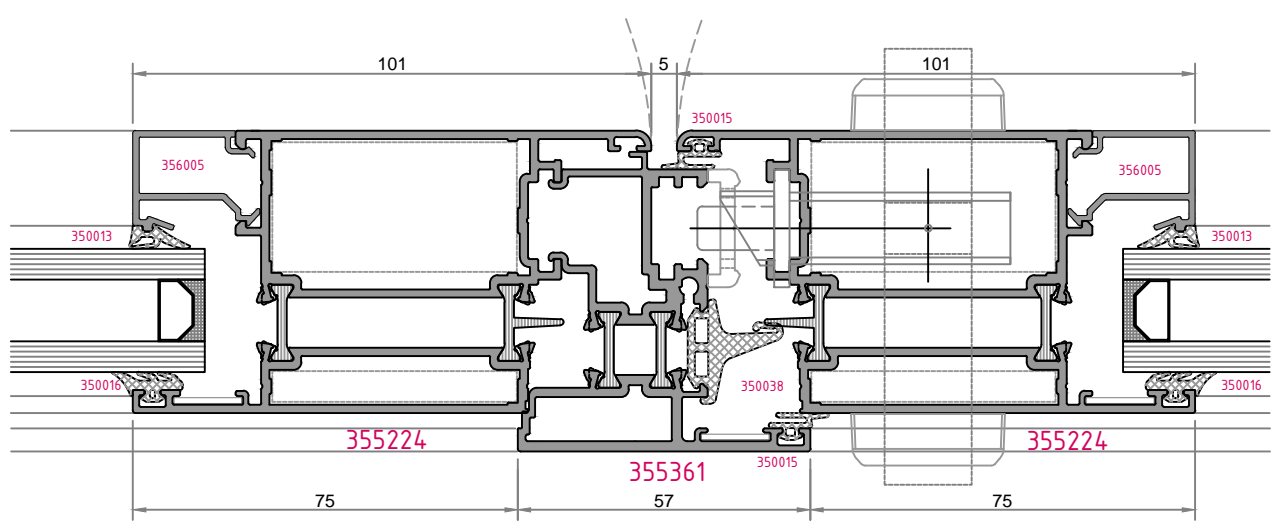

2b

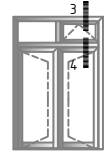

içe açılım kapı  
inside opening door

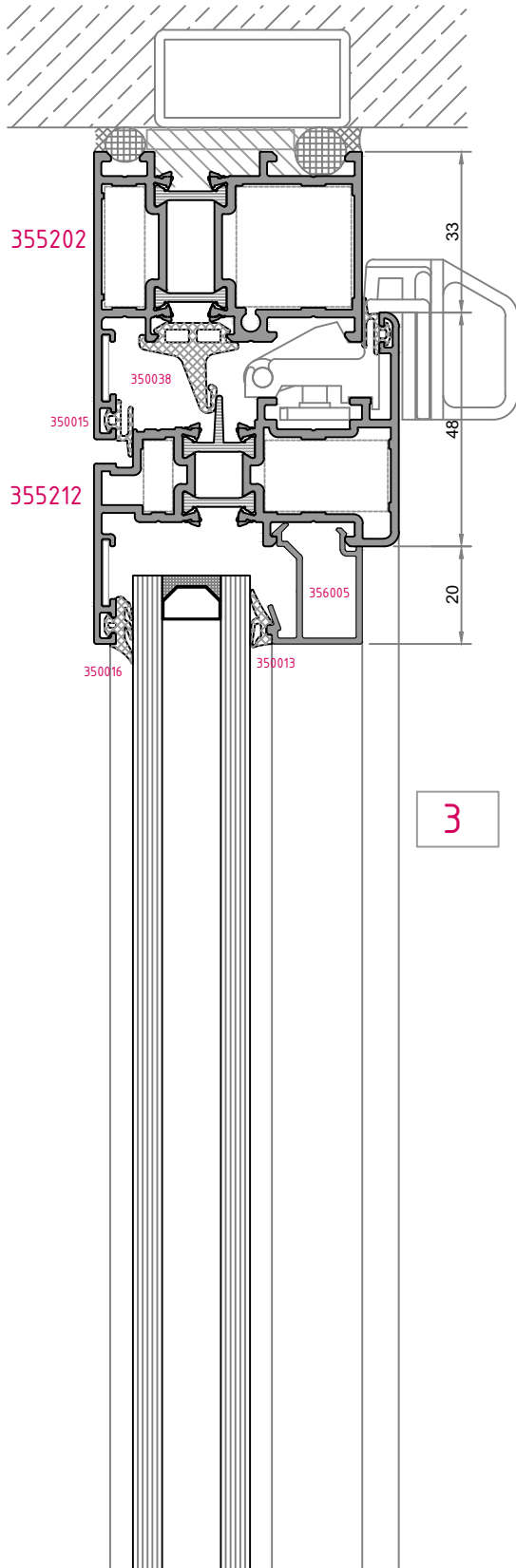

3

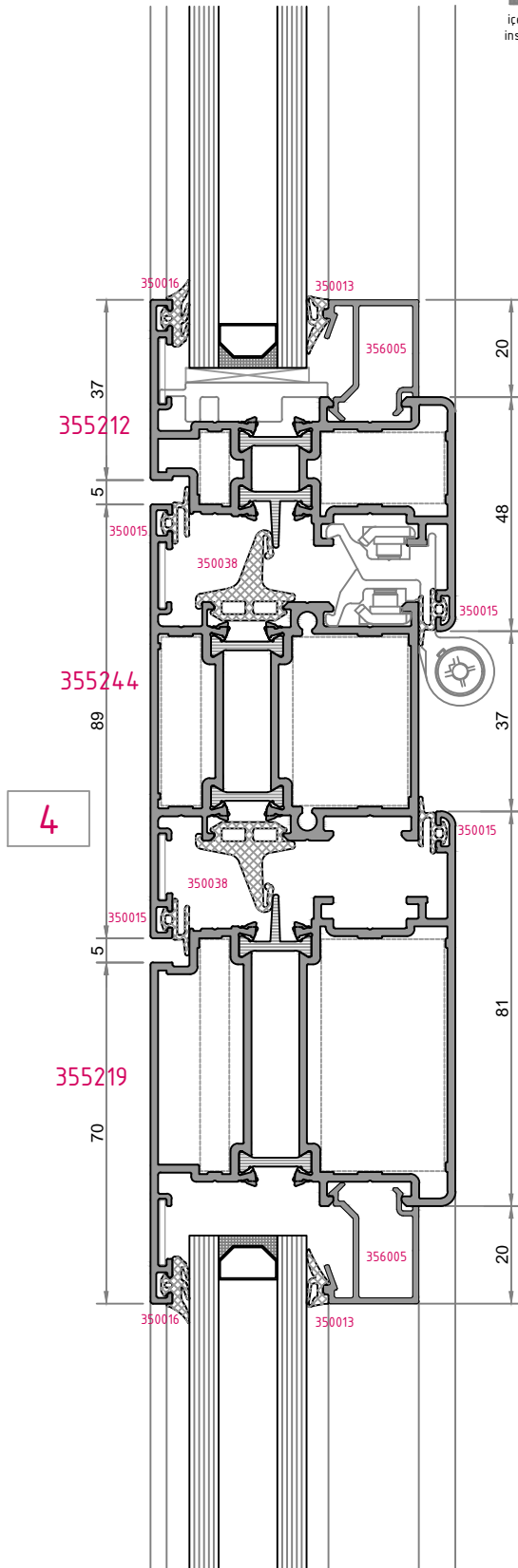

4

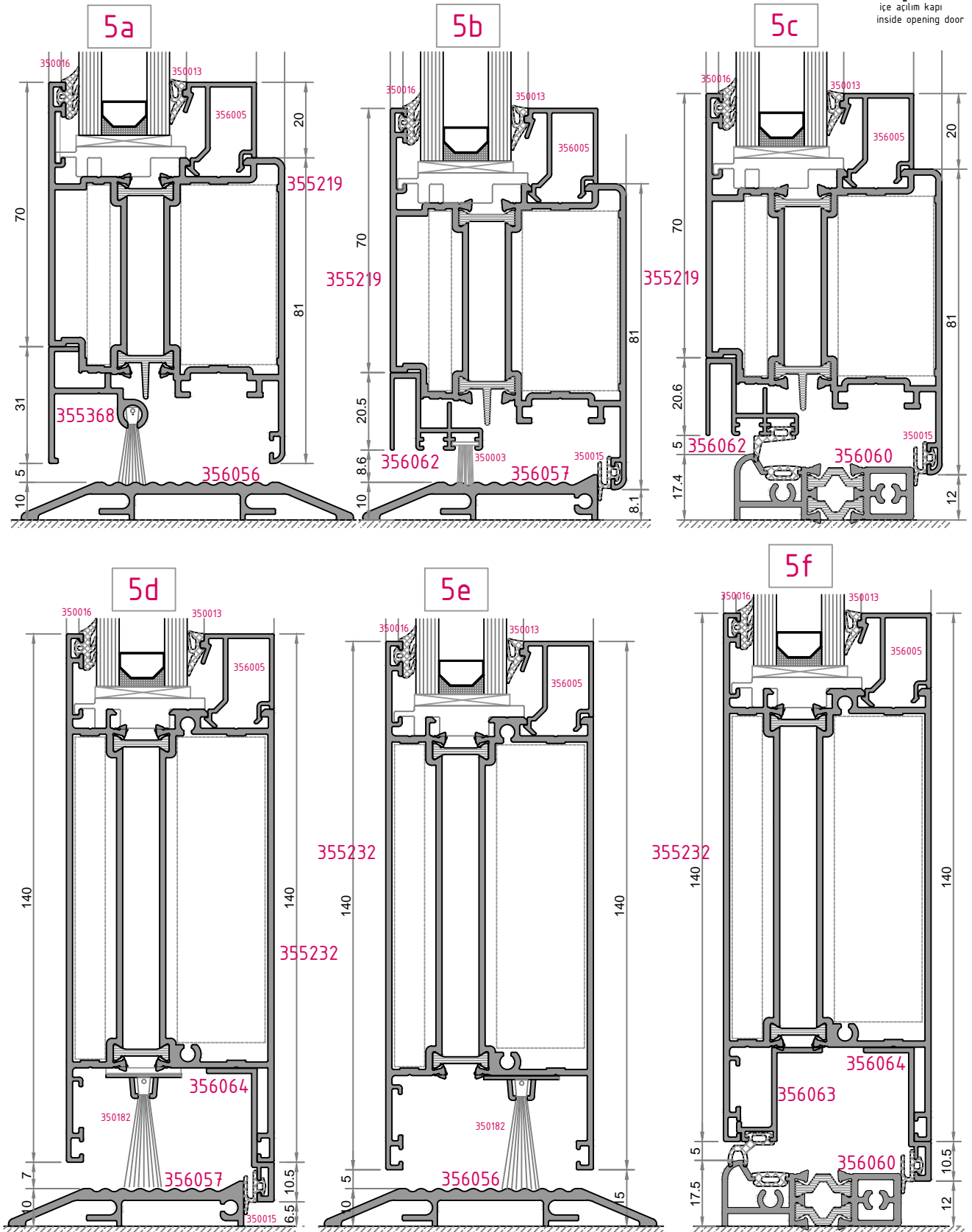

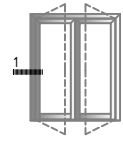

dışa açılım kapı  
outside opening door

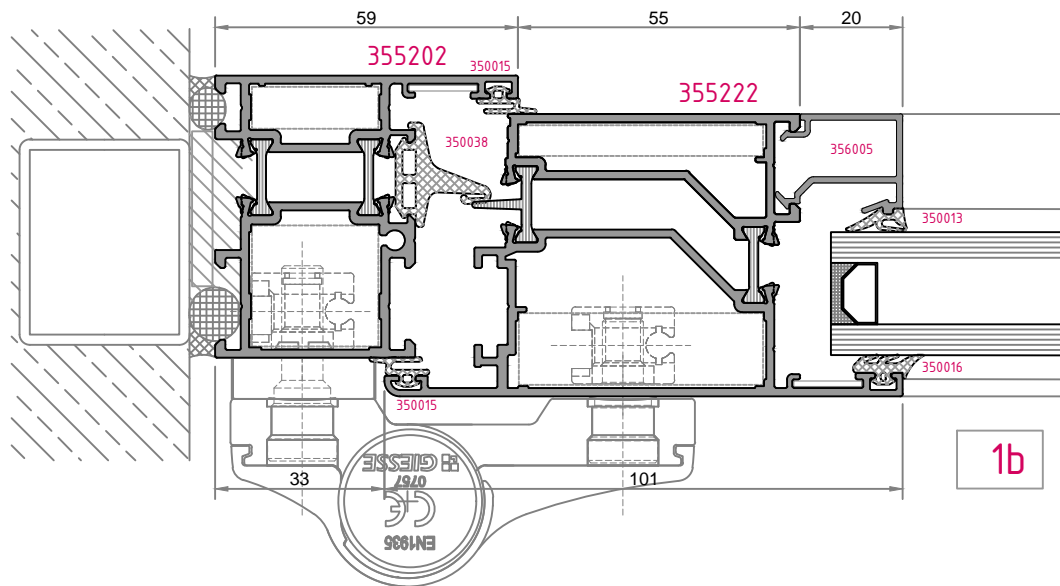
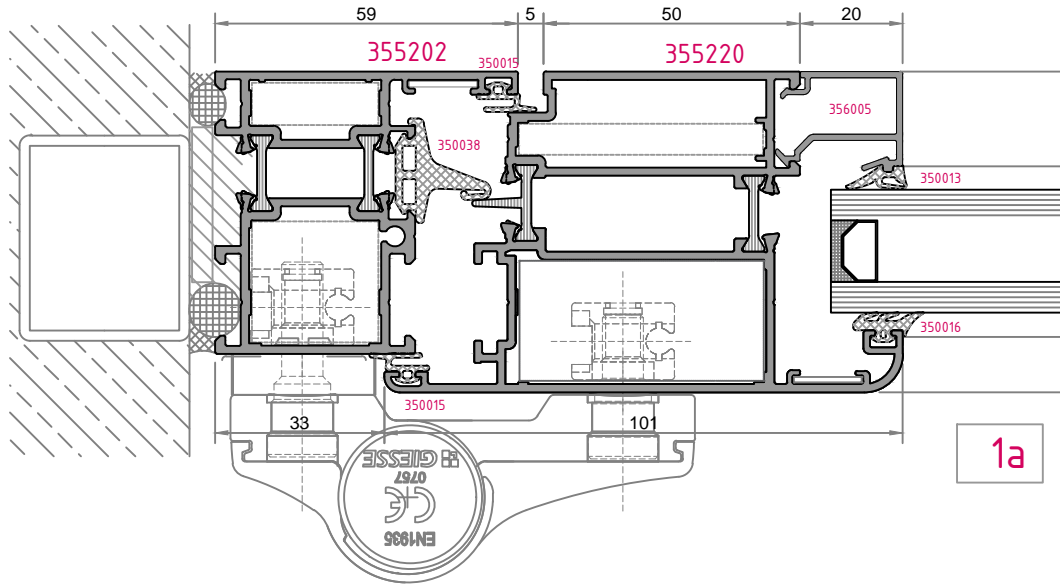

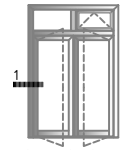

dişā acılım kapı  
outside opening door

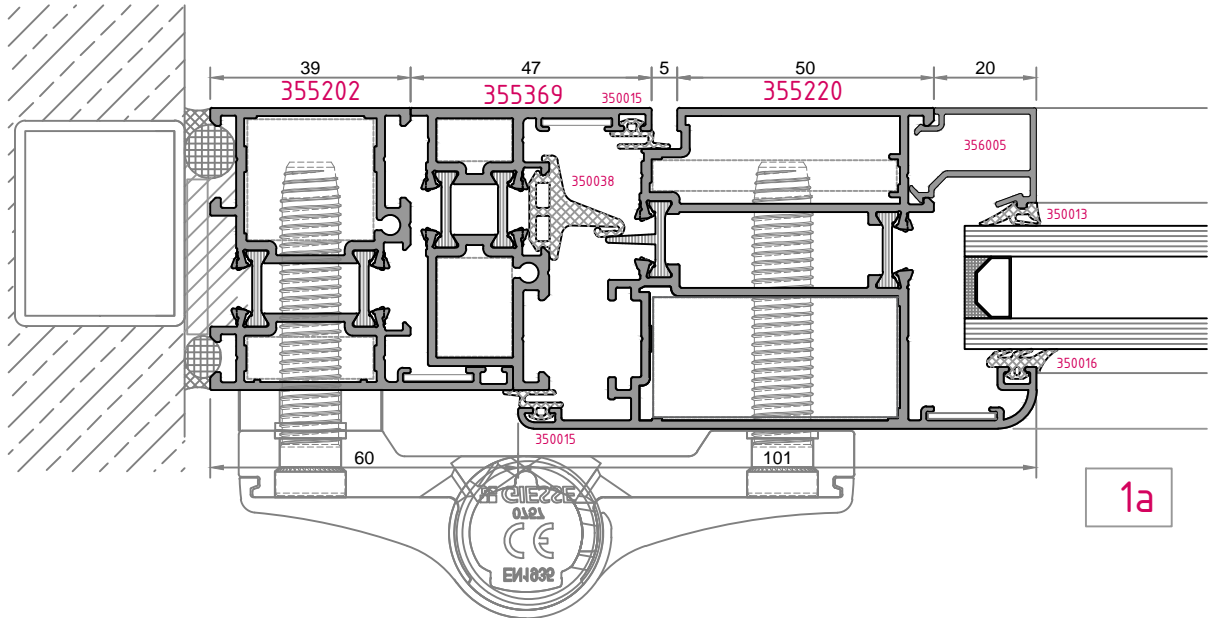

1a

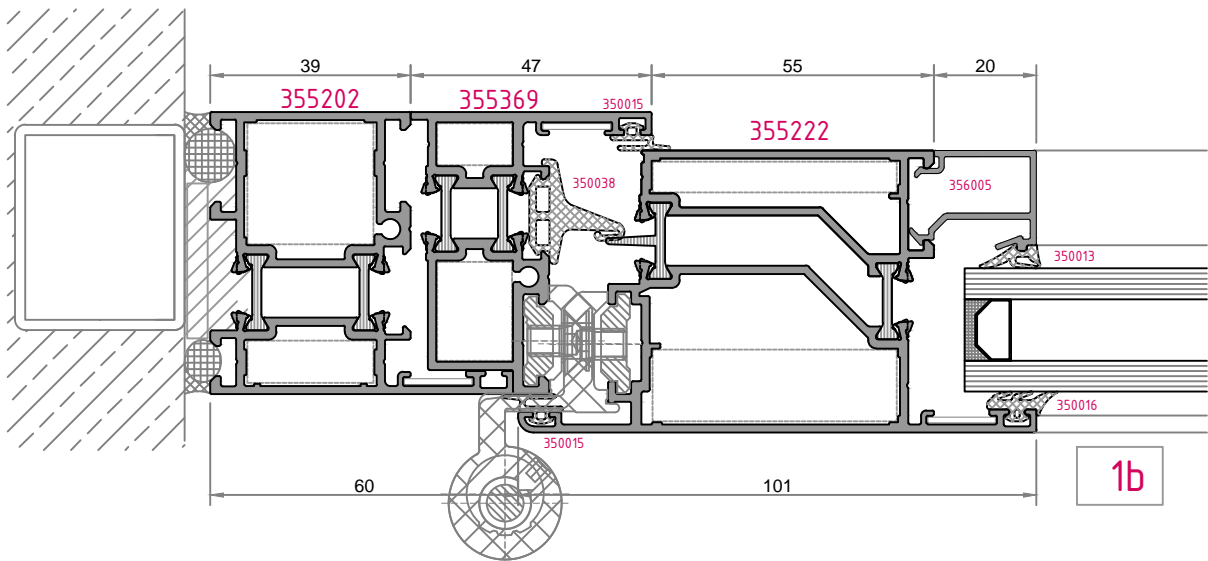

1b

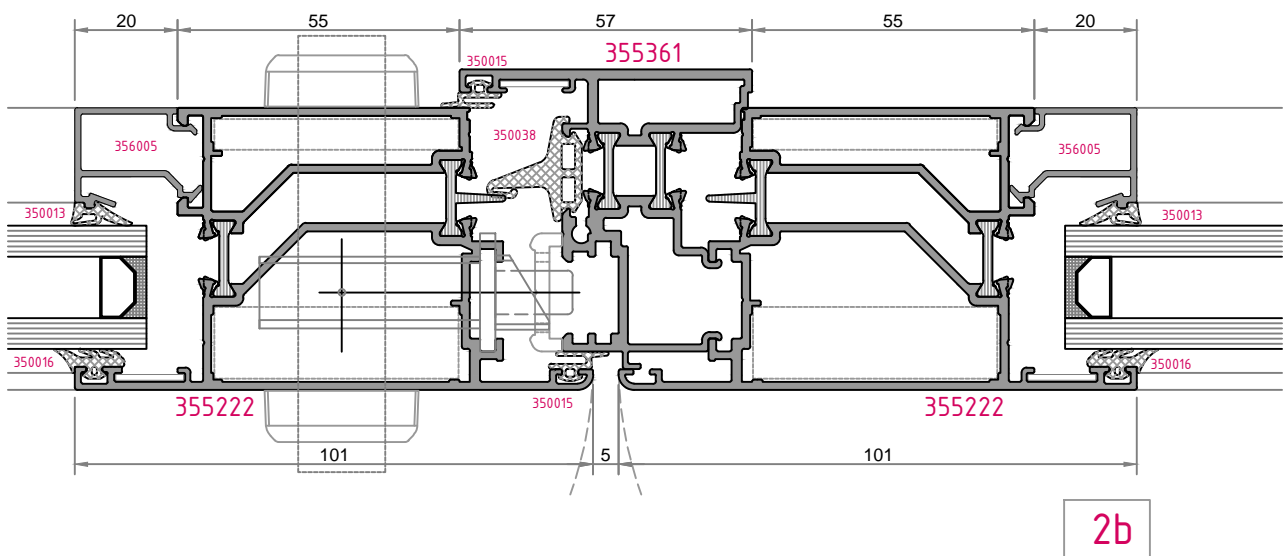
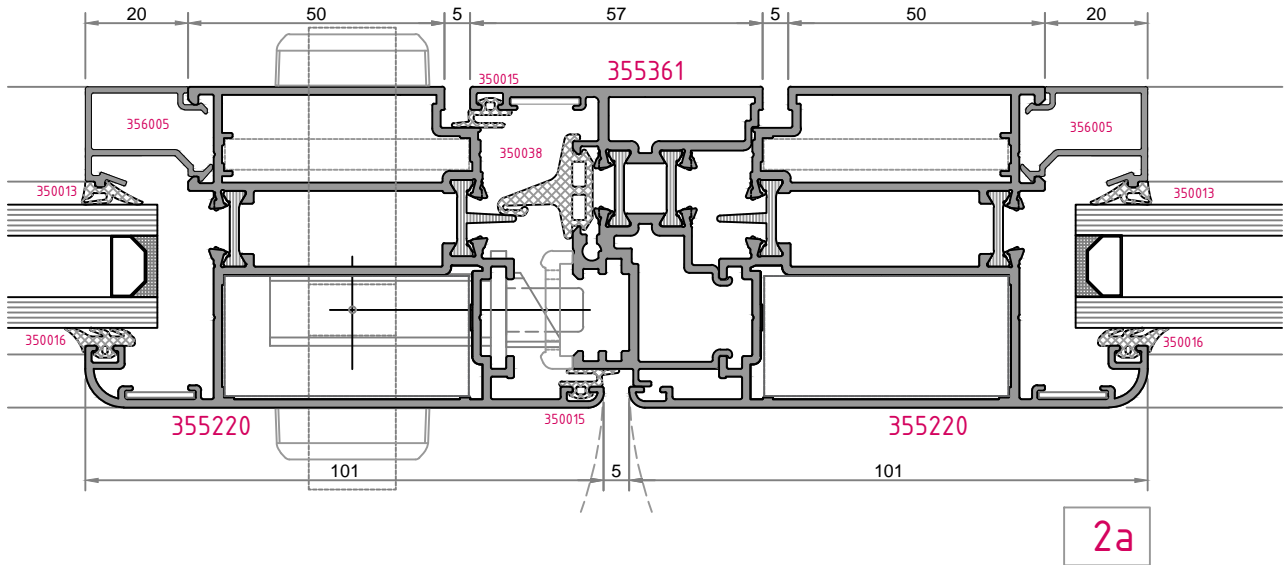
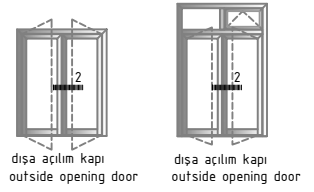





dışa açılım kapı  
outside opening door

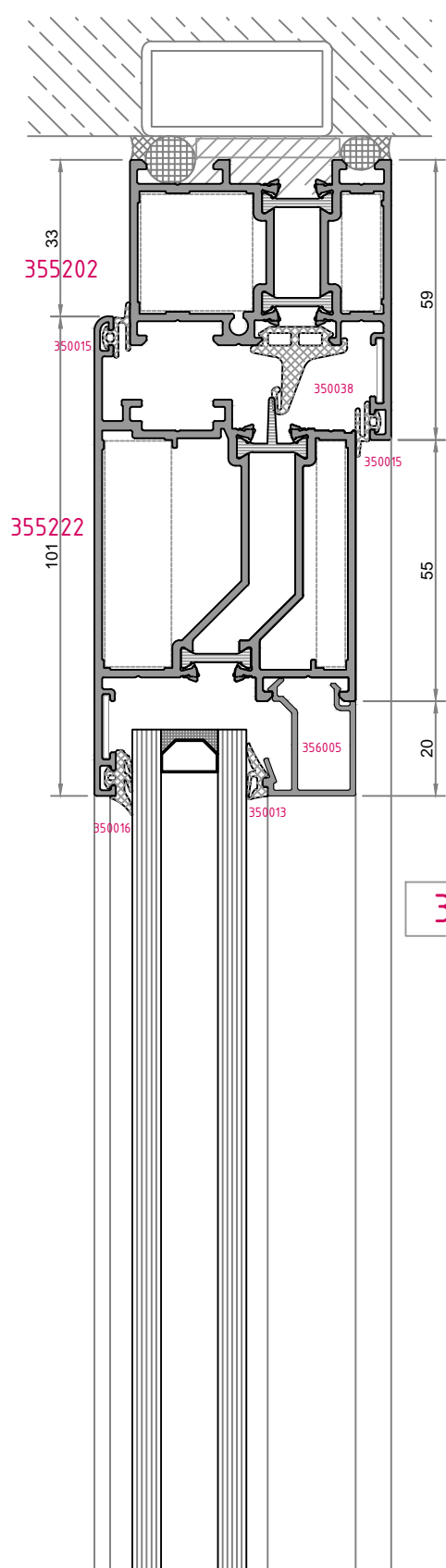
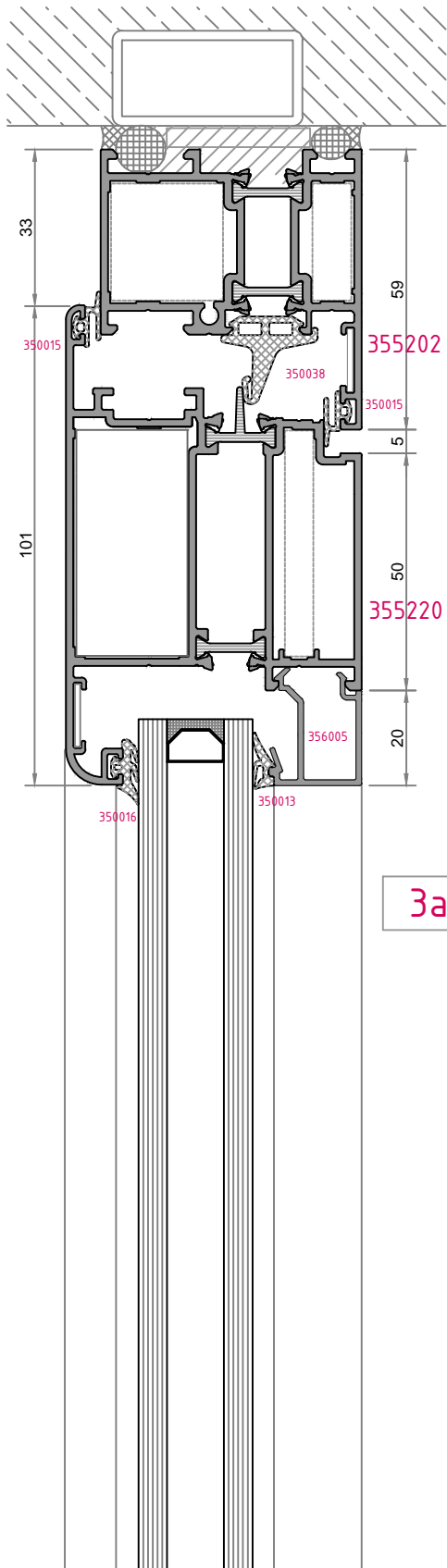

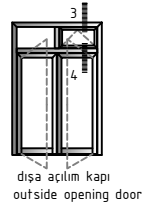
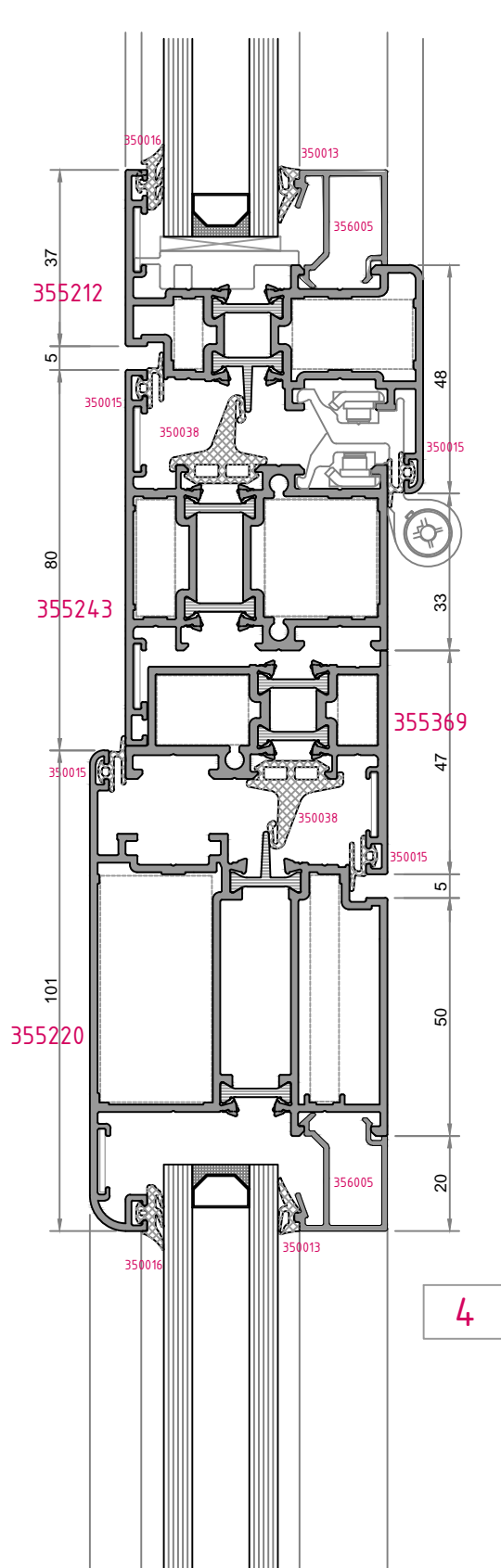
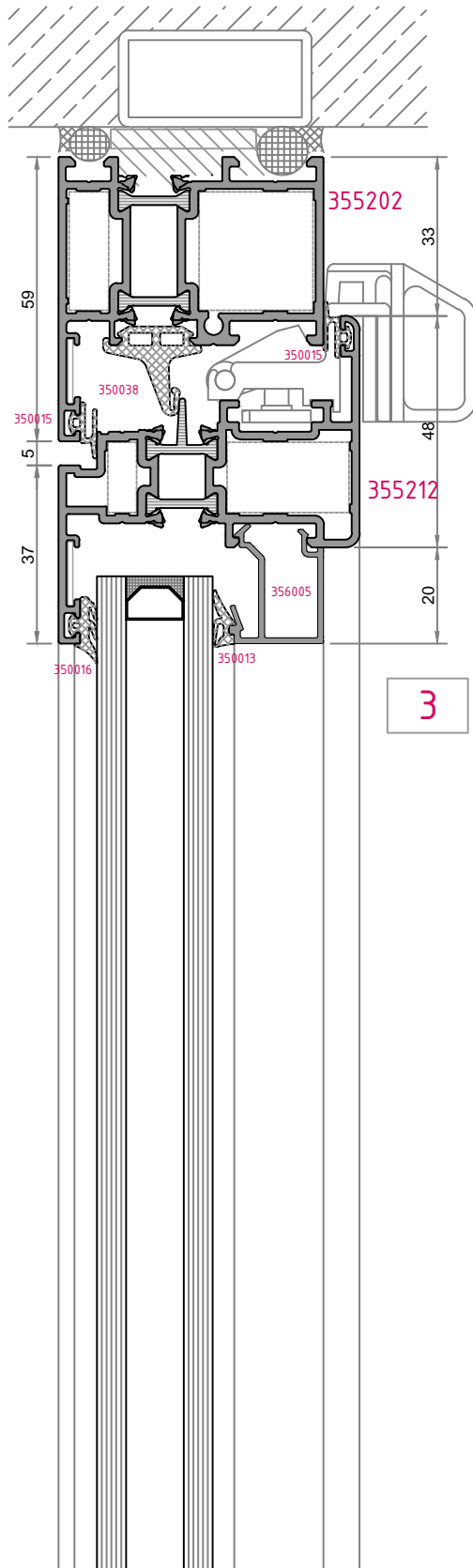

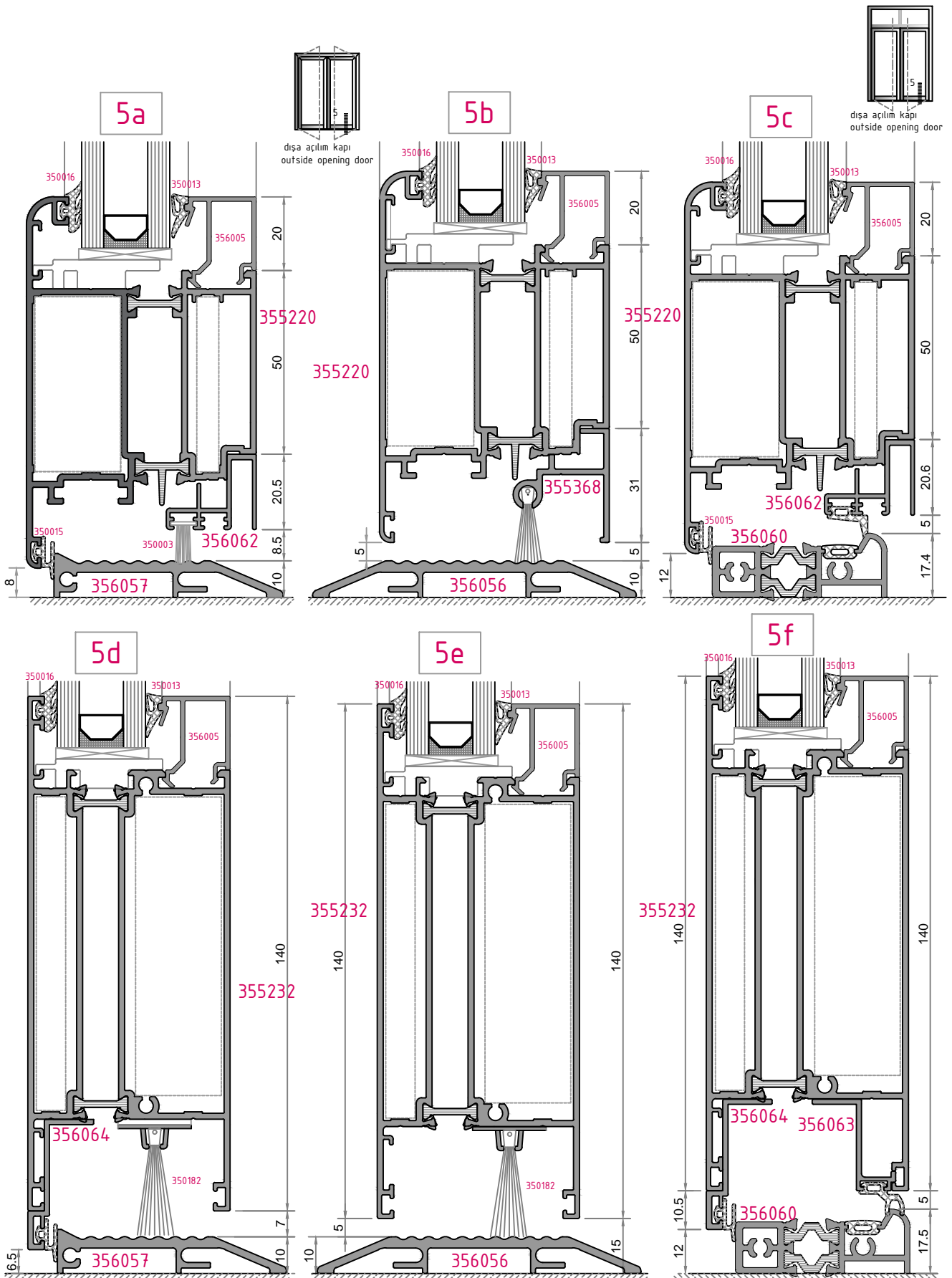

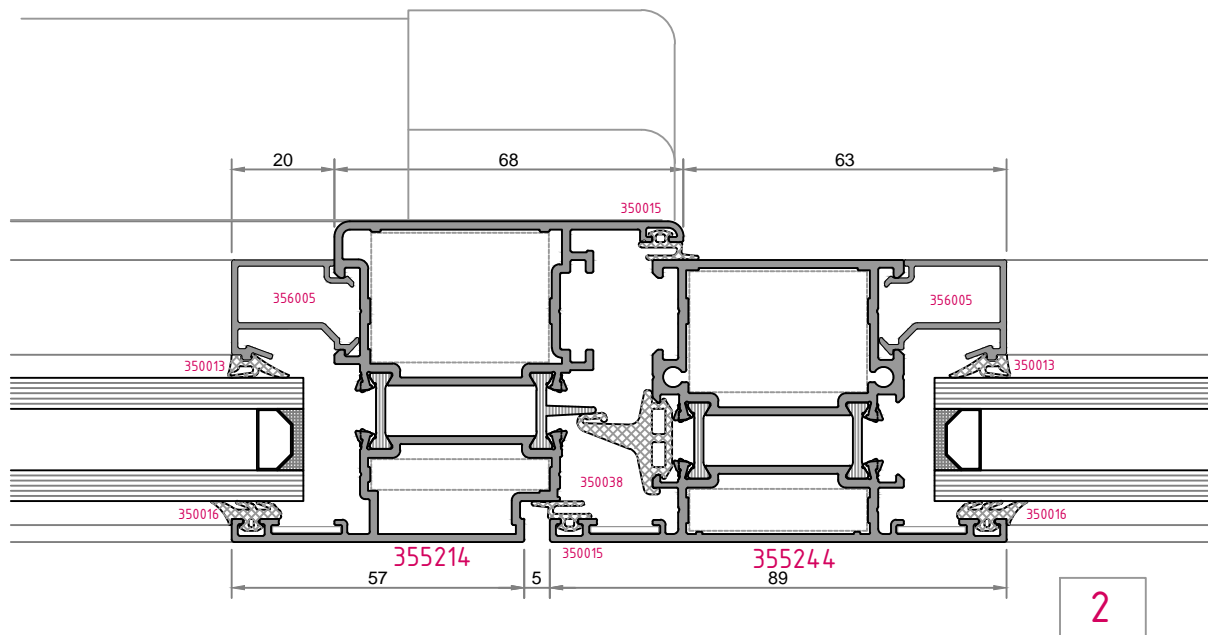
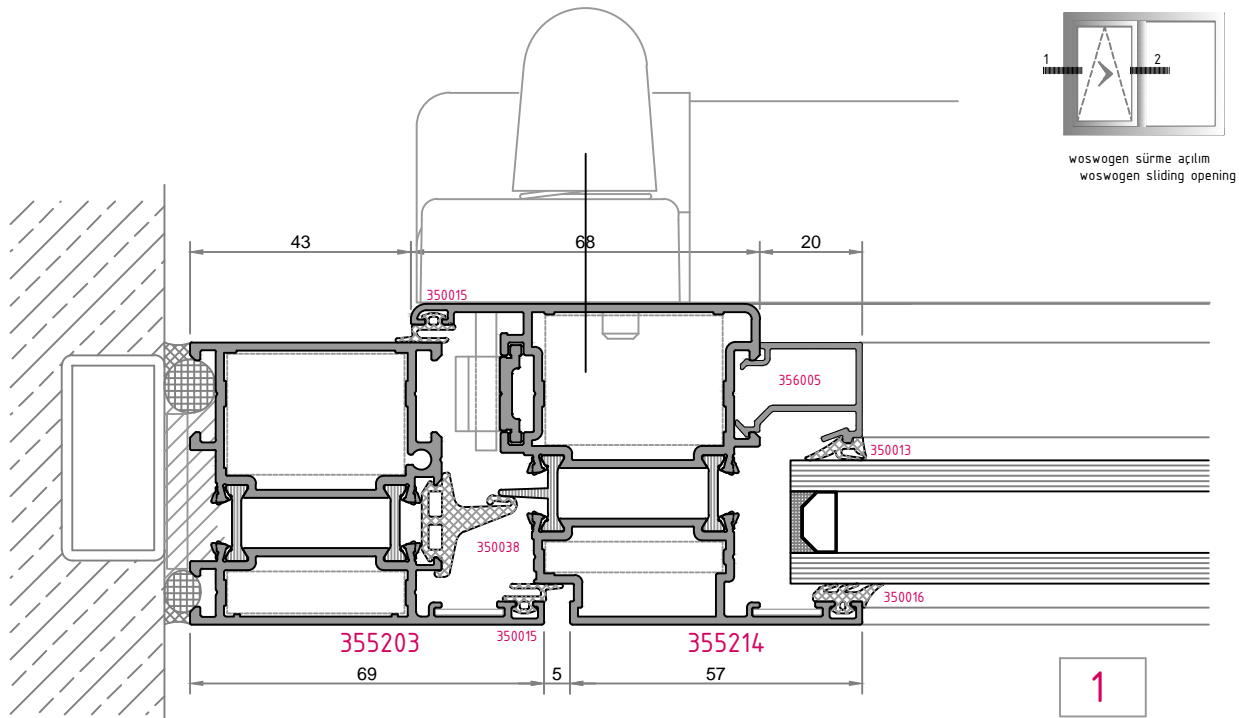

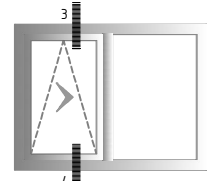
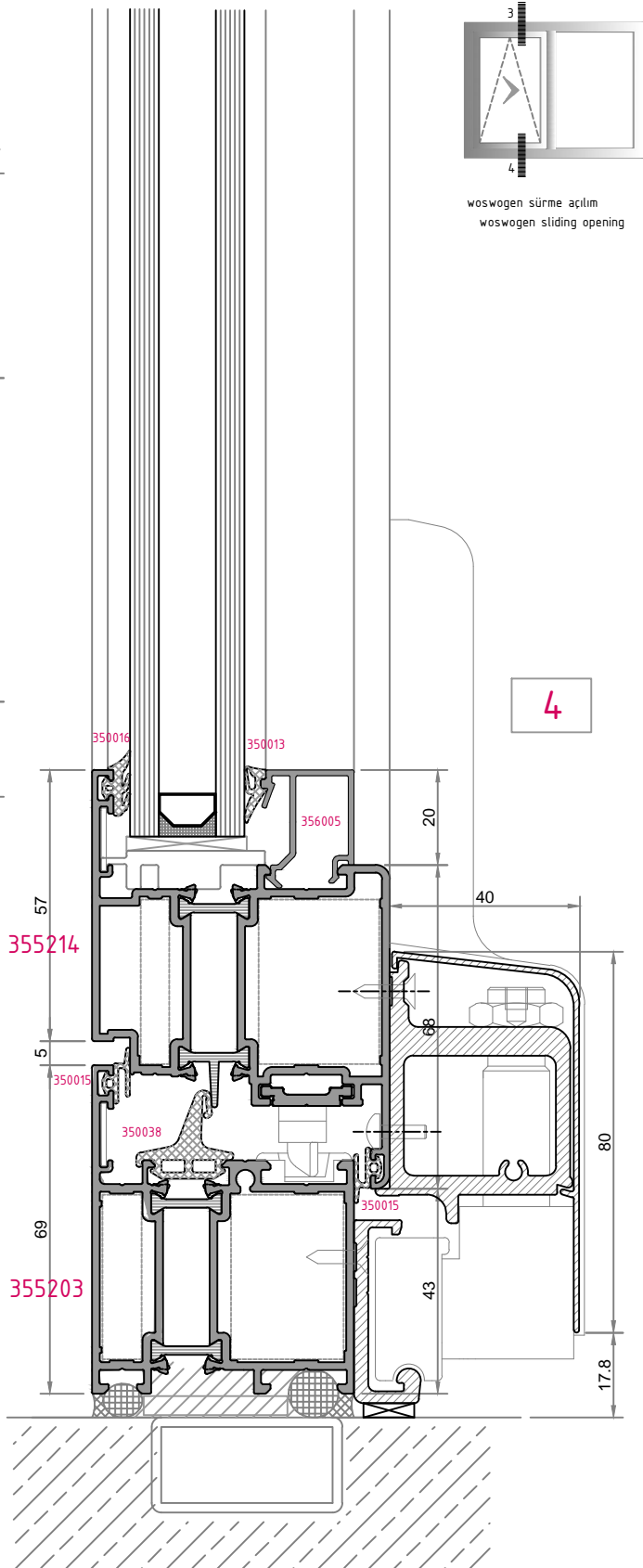
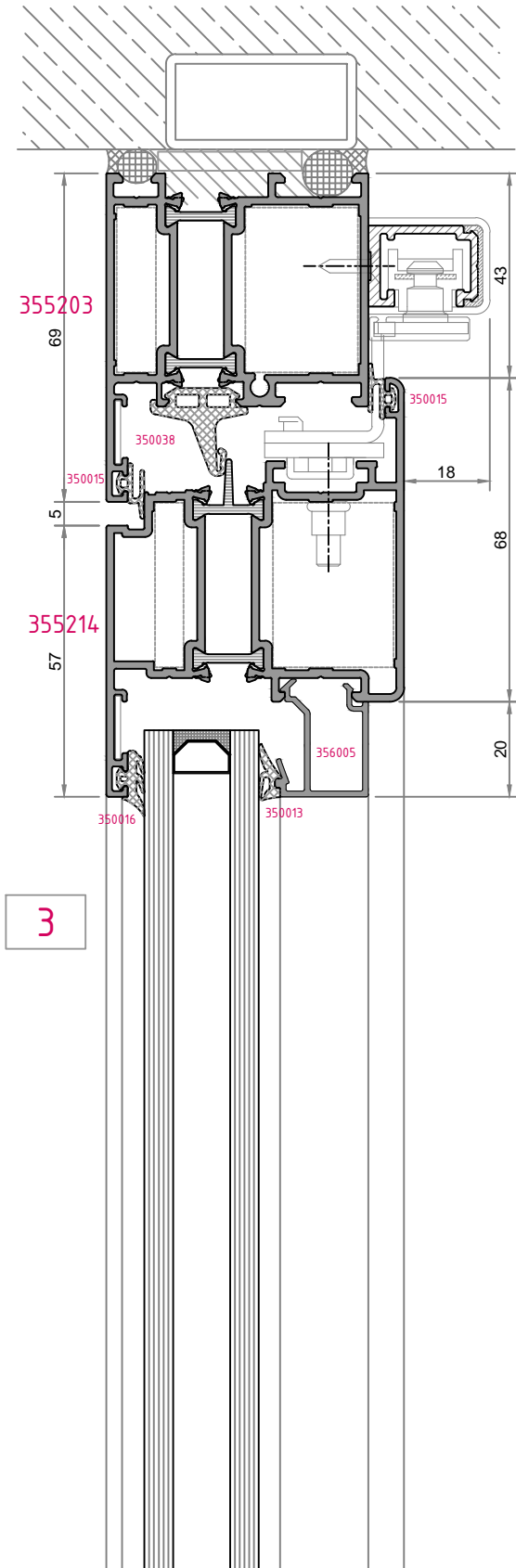

woswogen sürme açılım  
woswogen sliding opening

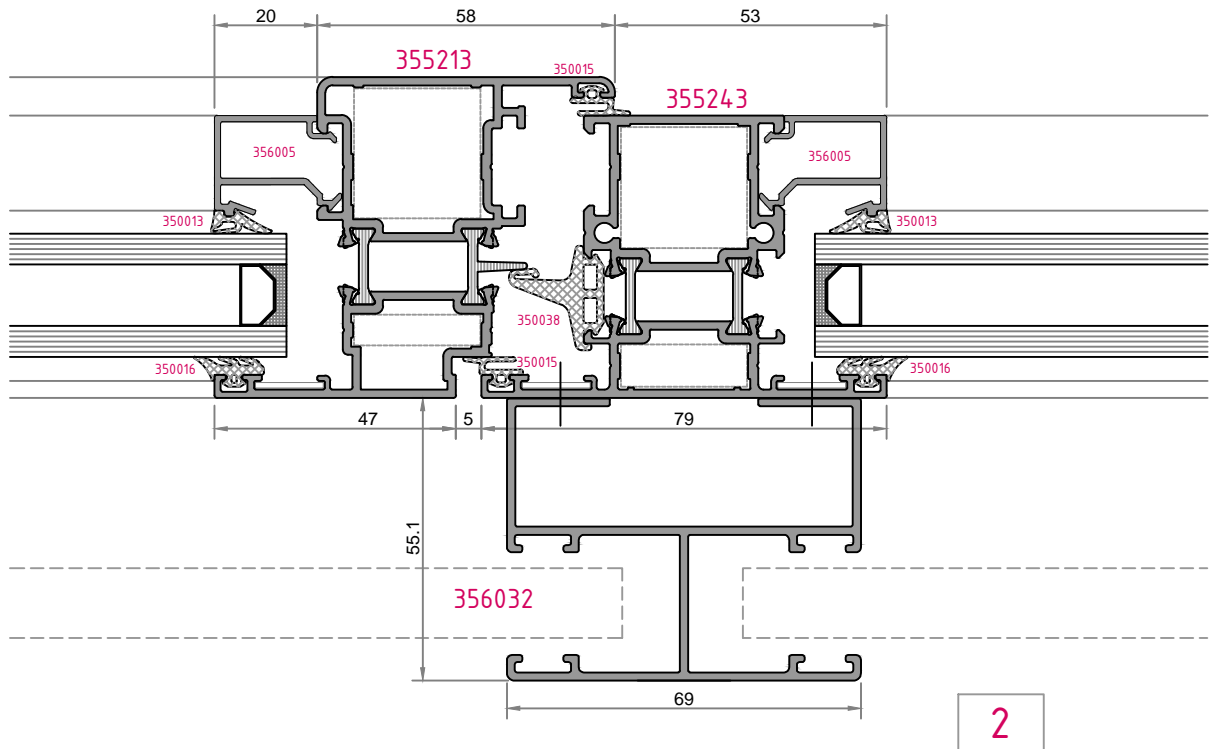
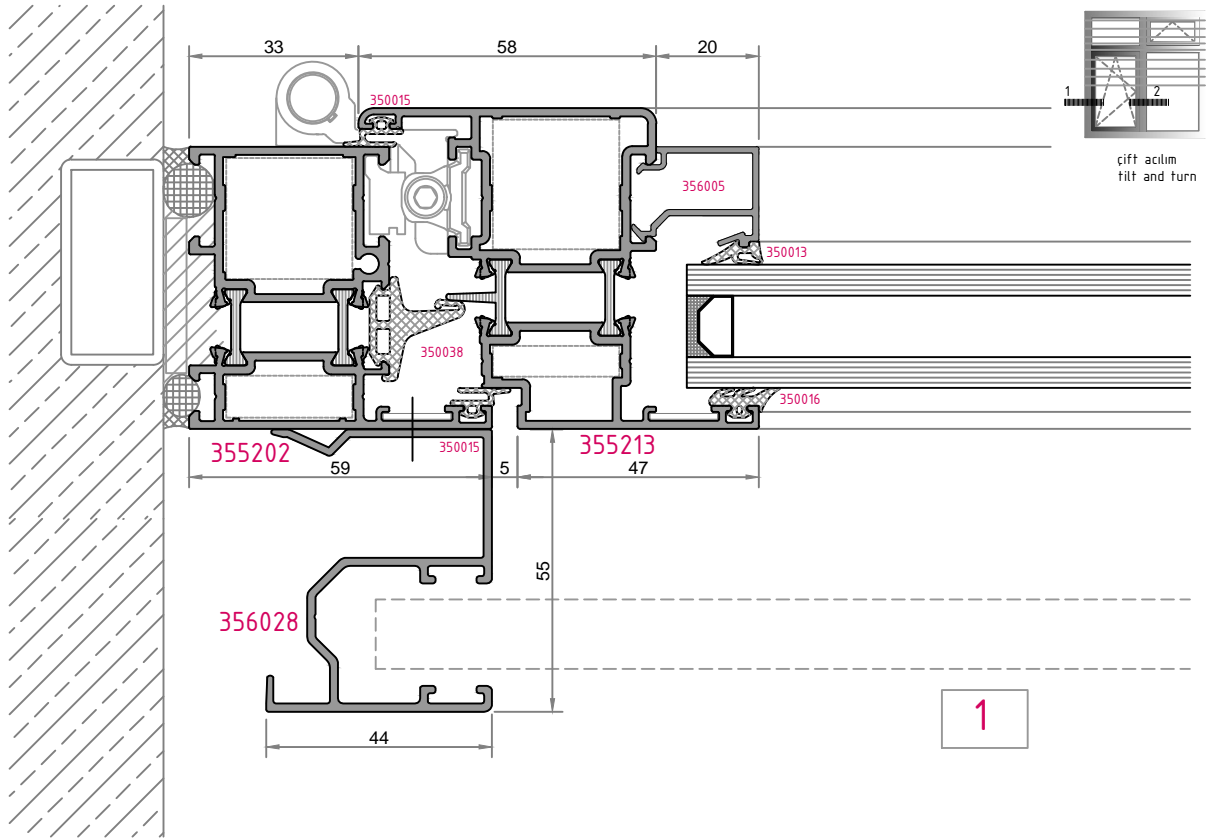

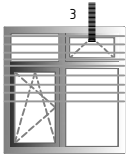

çift açılım  
filt and turn

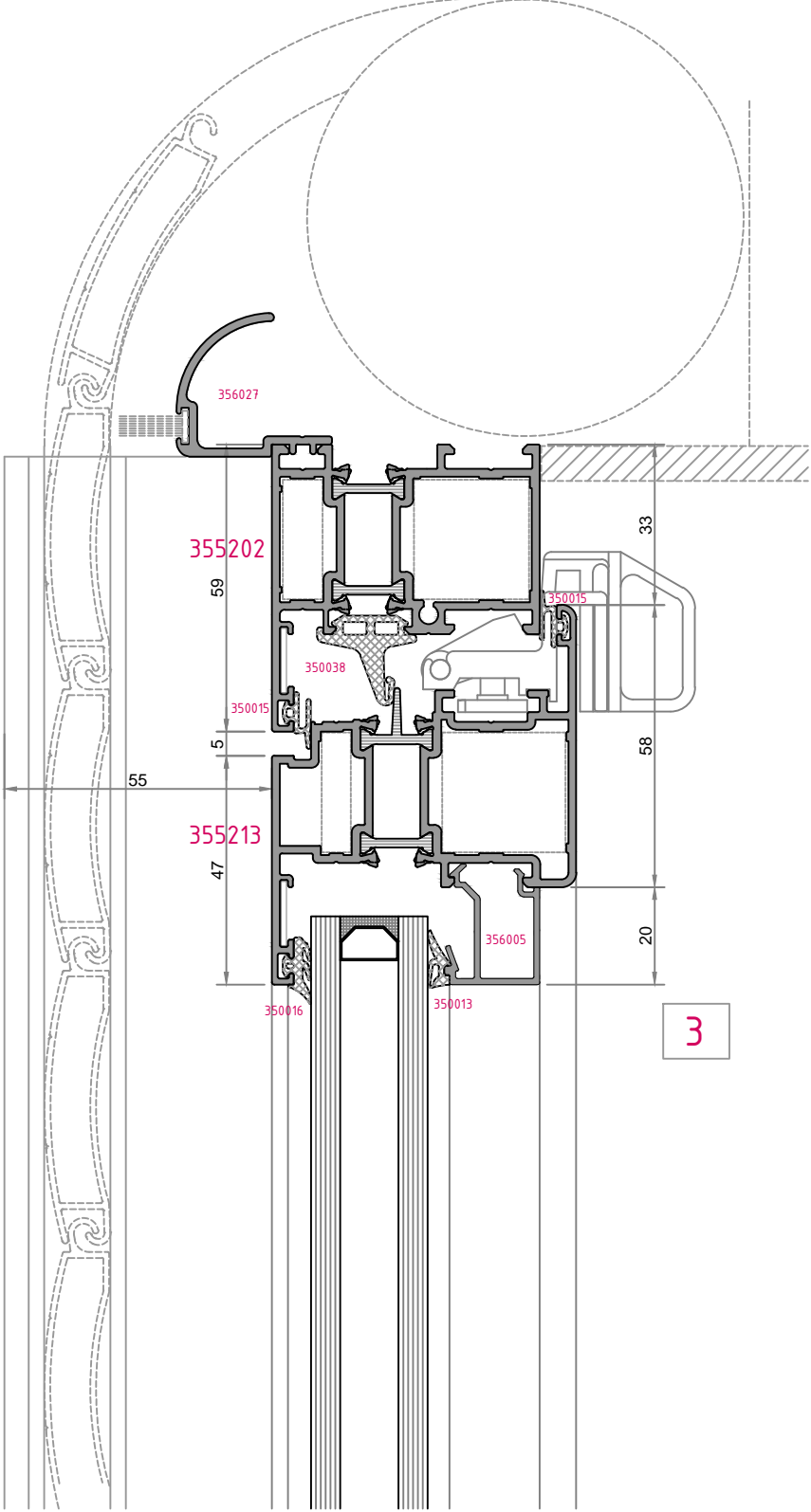

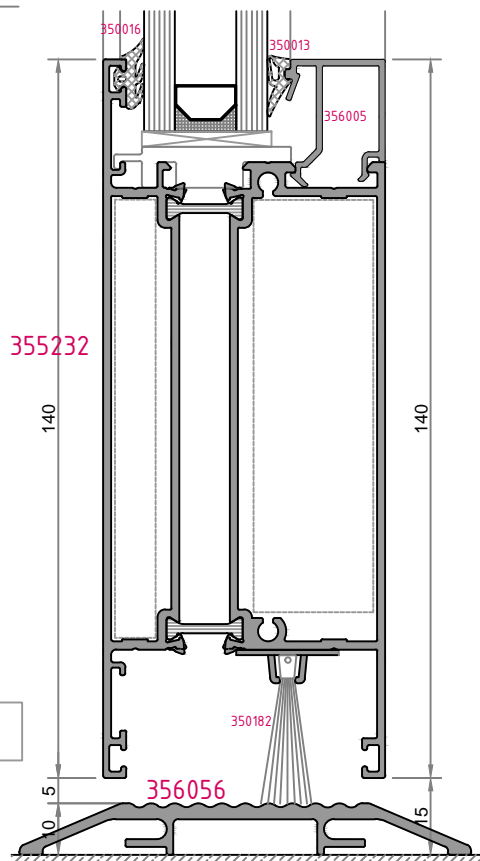
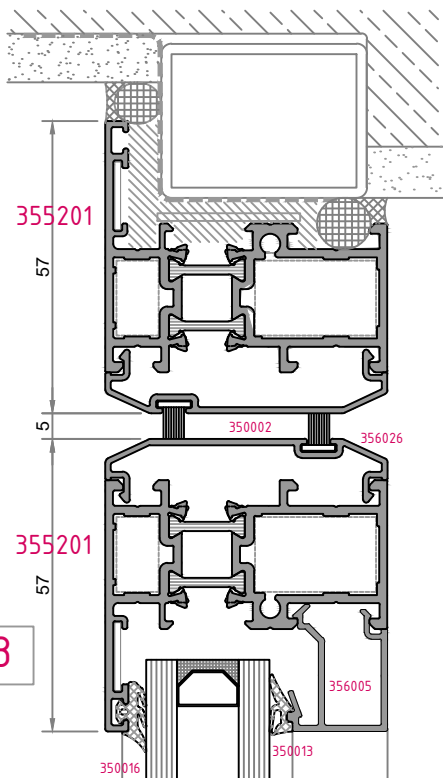
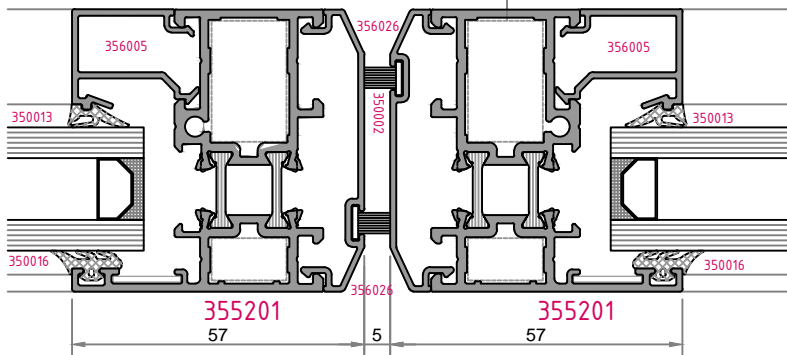
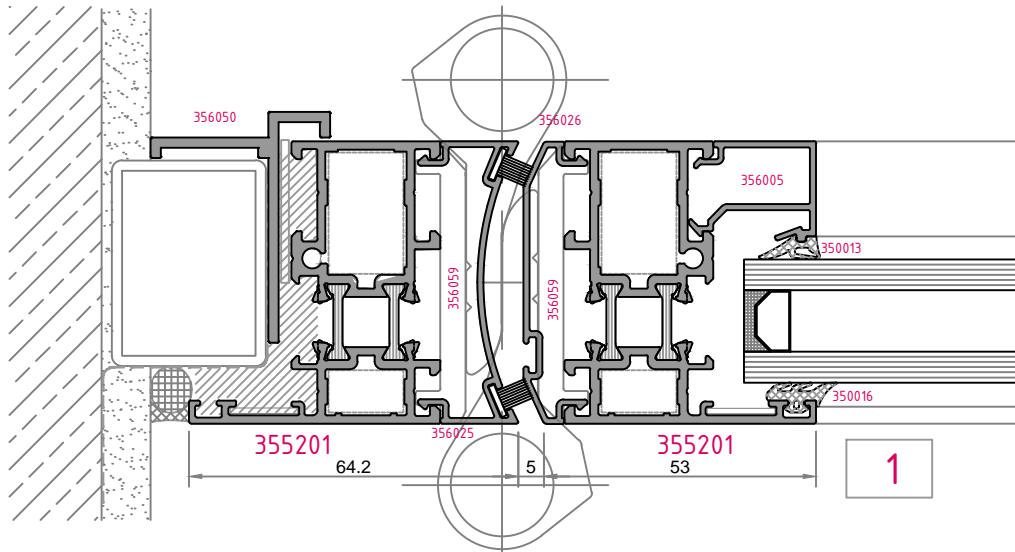



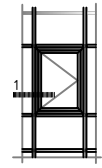

çephe içi  
içe açılım pencere  
inside opening casement  
for curtain wall

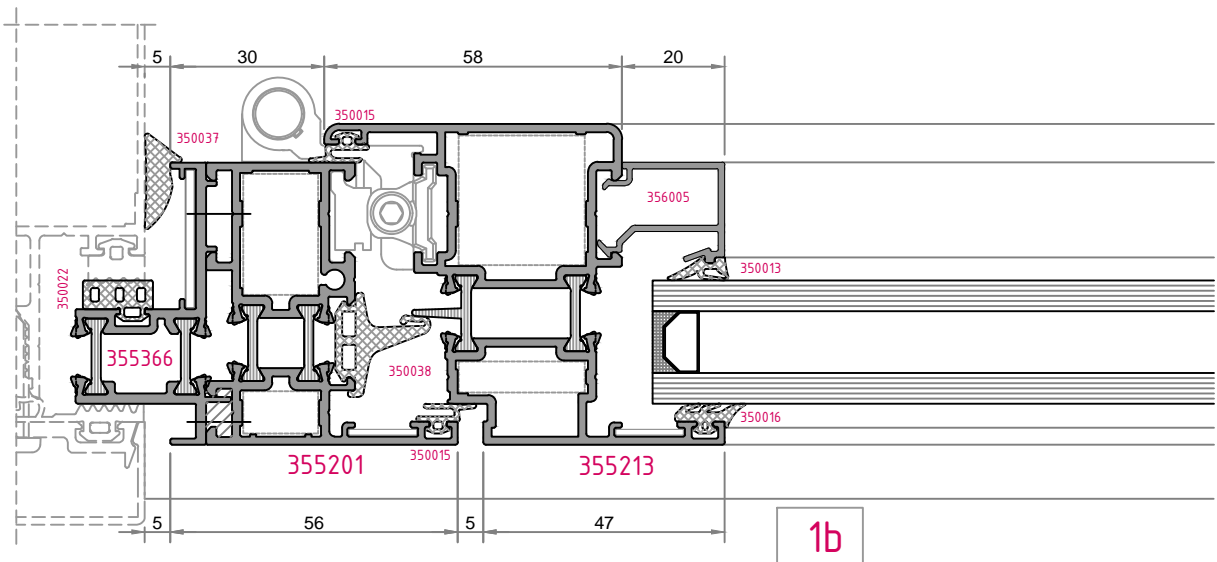
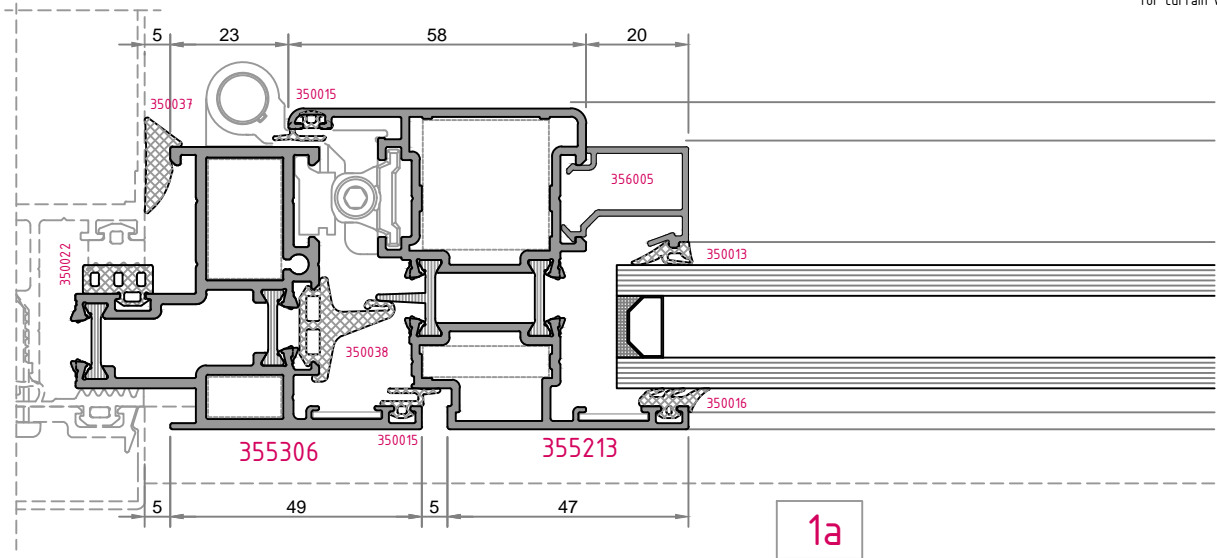

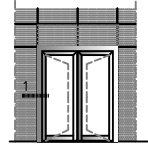

içe açılım kapı  
inside opening door

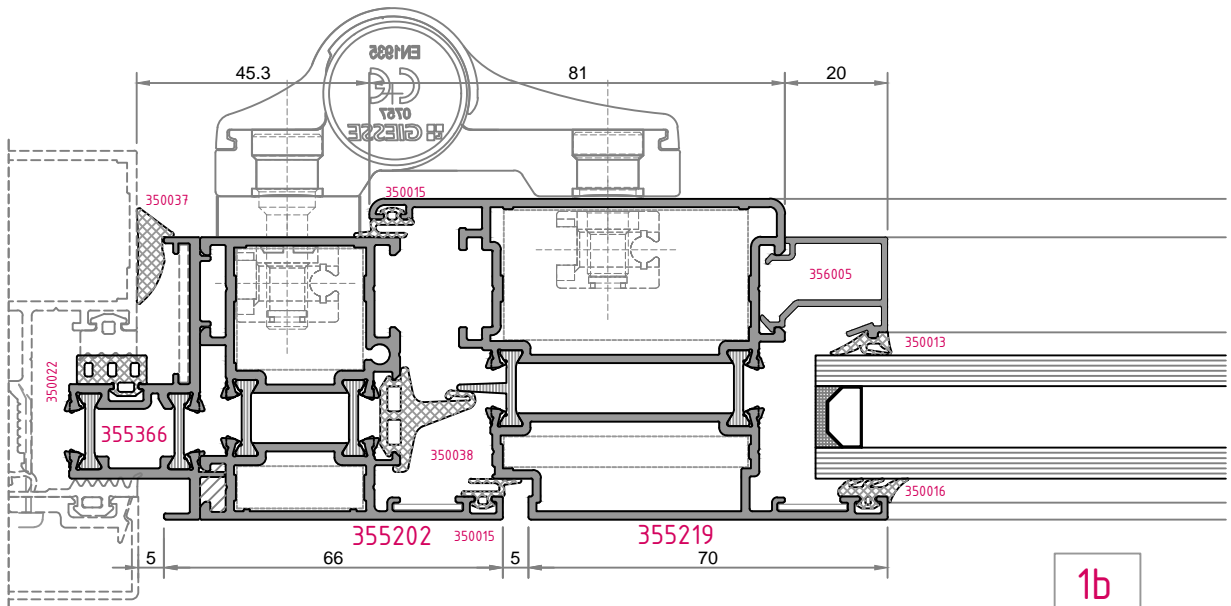
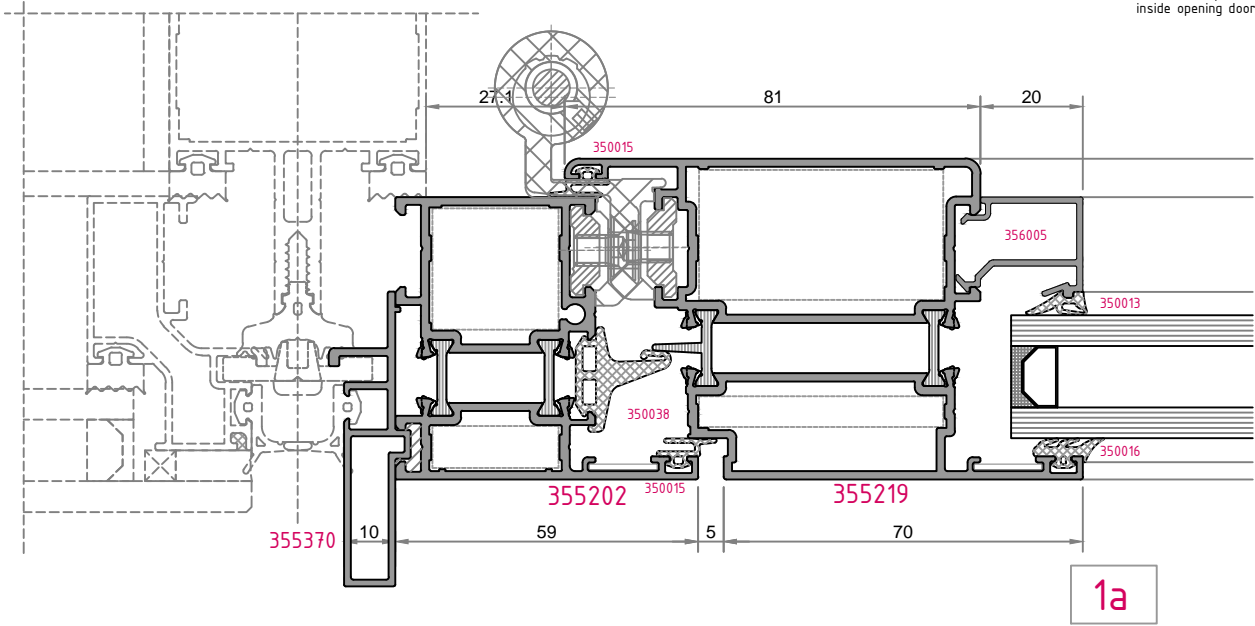

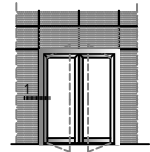

dışa açılım kapi  
outside opening door

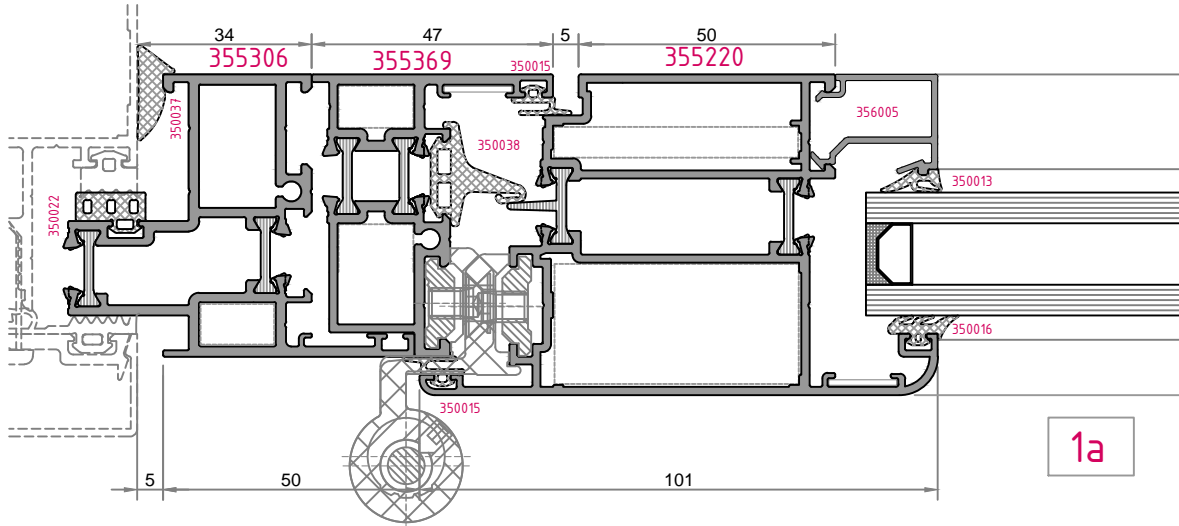

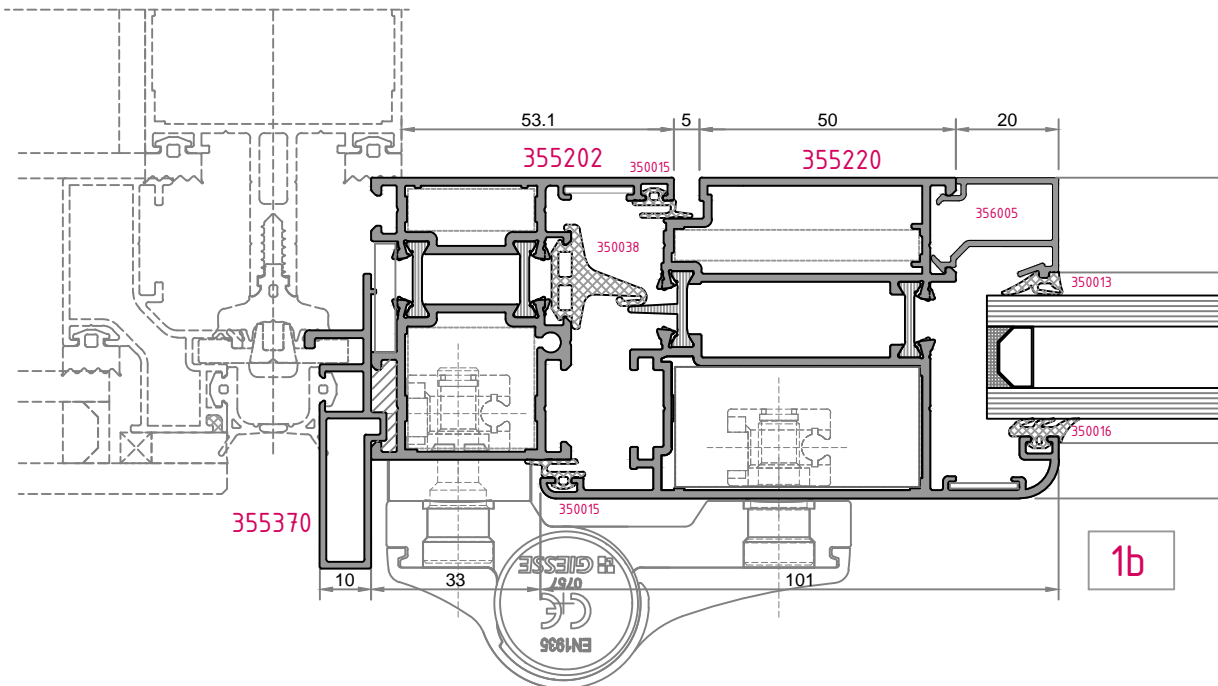

1a

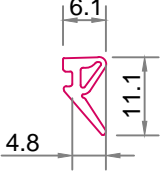
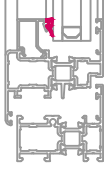
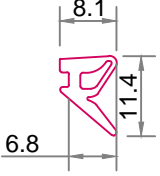
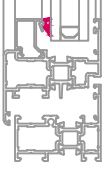
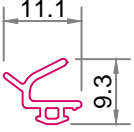
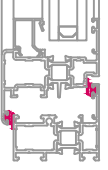
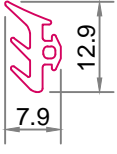
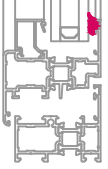
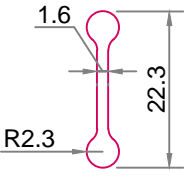
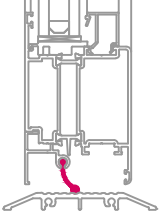
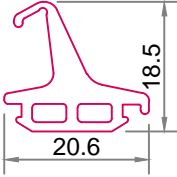
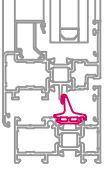
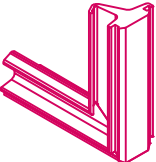
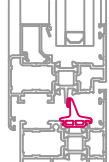

1b

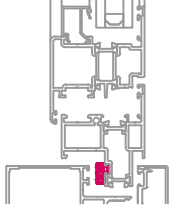
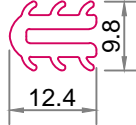
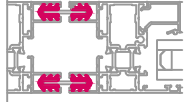
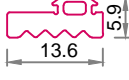
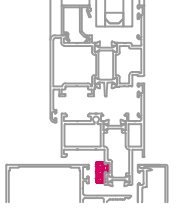
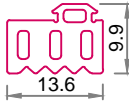
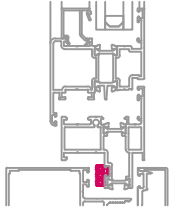
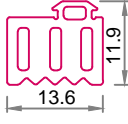
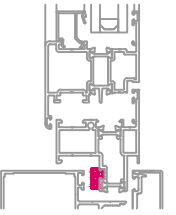
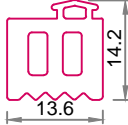
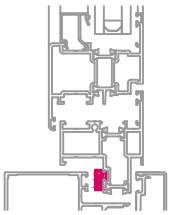
KOD Code	ŞEKİL Drawing	TANIM Description	METRAJİ In One Package	KULLANIM YERİ Application
350013		EPDM İç Cam Fiti		
350014		EPDM İç Cam Fiti		
350015		EPDM Kasa-Kanat Fiti		
350016		EPDM Dış Cam Fiti		
350021		EPDM Baza Alt Fiti		
350038		EPDM Kasa Orta Bini Fiti		
350039		EPDM Kasa Orta Fitil Köşe Parçası		

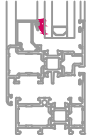
KOD Code	ŞEKİL Drawing	TANIM Description	METRAJİ in One Package	KULLANIM YERİ Application
350022		EPDM Açılım Adaptör İç Fitili		
350023		EPDM Profil Bağlantı Contası		
350025		EPDM Açılım Adaptör İç fitili		
350026		EPDM Açılım Adaptör İç fitili		
350027		EPDM Açılım Adaptör İç fitili		
350028		EPDM Açılım Adaptör İç fitili		
350032		EPDM İç Cam Kama Fitili		

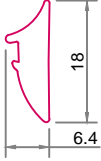
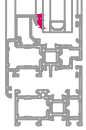
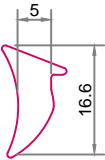
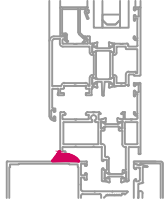
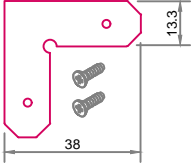
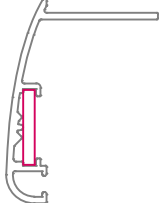
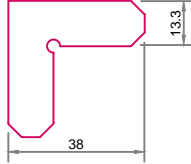
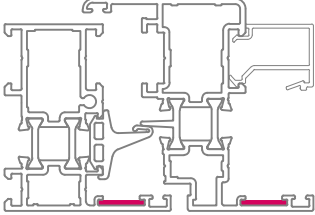
KOD Code	ŞEKİL Drawing	TANIM Description	METRAJİ in One Package	KULLANIM YERİ Application
350033		EPDM İç Cam Kama Fitili		
350037		EPDM Kasa Cam Kama Fitili		
350181		Köşe Birleştirme Aparatı Vidalı (Çavuş)		
350845		Köşe Birleştirme Aparatı Sıkıştırılmalı (Çavuş)		

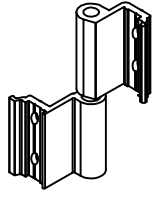

**İki yapraklı pencere menteşesi**  
Two leaves window hinge

W-830 (ithal) (import)	350550 (yerli) (native)	naturel eloksalli (mat anodized)
W-831 (ithal) (import)	350581 (yerli) (native)	pres veya renkli (mill finishand and painted)

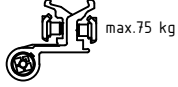

max.75 kg

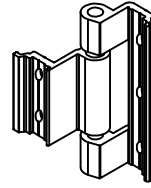

**Üç yapraklı pencere menteşesi**  
Three leaves window hinge

350535 (yerli) (native)	naturel eloksalli (mat anodized)
350536 (yerli) (native)	pres veya renkli (mill finishand and painted)

max.75 kg

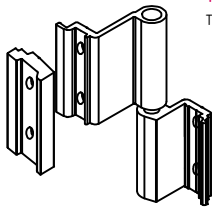

**İki yapraklı normal açılım pvc pencere menteşesi**  
Two leaves PVC window hinge

W-836 (ithal) (import)	W-836-a (yerli) (native)	naturel eloksalli (mat anodized)
W-837 (ithal) (import)	W-837-a (yerli) (native)	pres veya renkli (mill finishand and painted)

max.75 kg

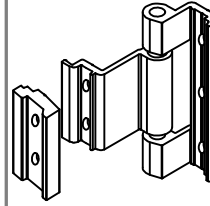

**Üç yapraklı normal açılım pvc pencere menteşesi**  
Three leaves PVC window hinge

350537 (yerli) (native)	naturel eloksalli (mat anodized)
350538 (yerli) (native)	pres veya renkli (mill finishand and painted)

max.75 kg

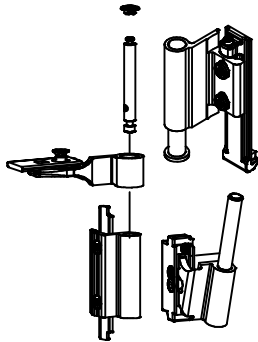

**Çift açılım pencere üst menteşesi (130kg)**  
Tilt and turn window top hinge (130kg)

350457 (ithal) (import)	naturel eloksalli (mat anodized)
350458 (ithal) (import)	pres veya renkli (mill finishand and painted)

**Çift açılım pencere üst menteşesi (80kg)**  
Tilt and turn window top hinge (80kg)

350459 (ithal) (import)	naturel eloksalli (mat anodized)
350460 (ithal) (import)	pres veya renkli (mill finishand and painted)

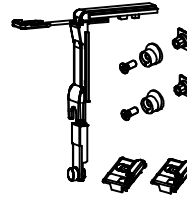

**Çift Açılım İlave Kilitleme**  
TILT AND TURN ANNEX SET

350472 (ithal) (import)
----------------------------

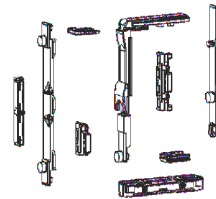

**Çift Açılım Kilitleme Mekanizması**  
TILT AND TURN BASE MECHANISM

350453 (ithal) (import)
----------------------------

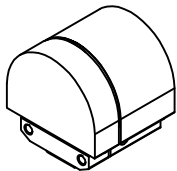

**Çift açılım pencere alt menteşesi**  
Tilt and turn window bottom hinge

350539 (ithal) (import)	W-848-a (yerli) (native)	naturel eloksalli (mat anodized)
350540 (ithal) (import)	W-849-a (yerli) (native)	pres veya renkli (mill finishand and painted)

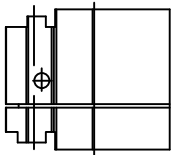

**Pivot menteşe**  
Hung window hinge

350541 (yerli) (import)	naturel eloksalli	FORMO SOLIS RARUS ACTUS
350542 (yerli) (import)	pers-renkli boyalı	

350543 (yerli) (import)	naturel eloksalli	PRIMUM CASTRUM
350544 (yerli) (import)	pers-renkli boyalı	

350545 (yerli) (import)	naturel eloksalli	INNOVATIO PERFECTUS
350546 (yerli) (import)	pers-renkli boyalı	

350547 (yerli) (import)	naturel eloksalli	GRACILIS FIXUM
350548 (yerli) (import)	pers-renkli boyalı	

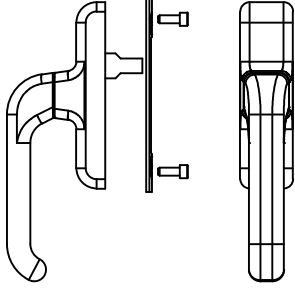

**Tek maçalı normal açılım pencere kolu**  
Opening window handle

350411 (yerli) (native)	350412 (yerli) (native)	naturel eloksalli (mat anodized)
350413 (yerli) (native)	350414 (yerli) (native)	pres veya renkli (mill finishand and painted)

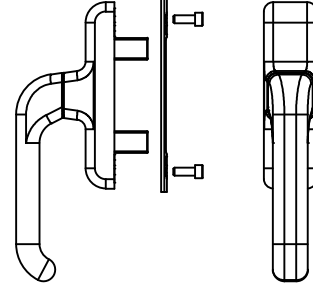

**Çift maçalı normal açılım pencere kolu**  
Opening window handle

350415 (ithal) (import)	350416 (yerli) (native)	naturel eloksalli (mat anodized)
350417 (ithal) (import)	350418 (yerli) (native)	pres veya renkli (mill finishand and painted)



**Anahtarlı eksenel kol**  
Key lockable window handle

W-860 (ithal) (import)	W-860-a (yerli) (native)	naturel eloksalli (mat anodized)
W-861 (ithal) (import)	W-861-a (yerli) (native)	pres veya renkli (mill finishand and painted)



**Sökülebilir kol gövde**  
Opening window removing handle

W-863 (ithal) (import)	W-863-a (yerli) (native)	naturel eloksalli (mat anodized)
W-864 (ithal) (import)	W-864-a (yerli) (native)	pres veya renkli (mill finishand and painted)

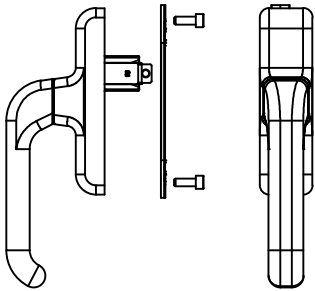

**Çift açılım pencere kolu**  
Tilt and turn opening window handle

350437 (ithal) (import)	350438 (yerli) (native)	naturel eloksalli (mat anodized)
350439 (ithal) (import)	350439 (yerli) (native)	pres veya renkli (mill finishand and painted)



**Limitleme makası (küçük)**  
Window stay (small)

350483 (ithal) (import)	350484 (yerli) (native)
----------------------------	----------------------------



**Limitleme makası (büyük)**  
Window stay (big)

350481 (ithal) (import)	350482 (yerli) (native)
----------------------------	----------------------------



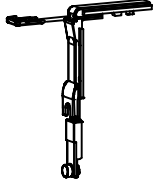

**Köşe hareket aktarıcı**  
Corner transmission for window

350461 (ithal) 350462 (yerli)  
(import) (native)



**Pim karşılığı**  
Adjustable single striker

350463 (ithal) 350464 (yerli)  
(import) (native)

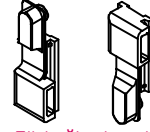

**Tij bağlantı pabucu**  
Connection blocks

350465 (ithal) 350466 (yerli)  
(import) (native)



**Pim**  
Pin

350467 (ithal) 350468 (yerli)  
(import) (native)



**Ayarlanabilir pim**  
Adjustable fastening pawl

350469 (ithal) 350470 (yerli)  
(import) (native)

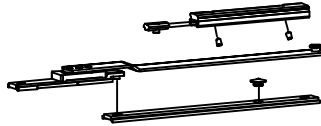

**Çift açılım ilave makas**  
Tilt and turn annex arm

350471 (ithal) 350472 (yerli)  
(import) (native)



**Kol karşılığı**  
Cremone drive

350477 (ithal) (import)  
W-882-a (yerli) (native)



**Sürgü ucu**  
Bolt tip

350478 (ithal) (import)  
W-883-a (yerli) (native)

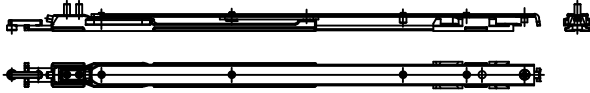

**Çift açılım büyük makas (130kg)**  
Tilt and turn long arm (130kg)

350475 (ithal) W-881-80-a (yerli) 350476 (ithal) W-881-130-a (yerli)  
(import) (native) (import) (native)

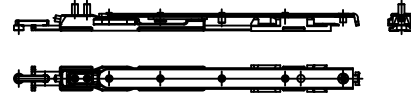

**Çift açılım küçük makas (80kg)**  
Tilt and turn short arm (80kg)

350473 (ithal) W-884-80-a (yerli) 350474 (ithal) W-884-130-a (yerli)  
(import) (native) (import) (native)

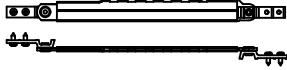

**Kademeli teleskopik makas (inox)**  
Telescopic laser unit

350479 (ithal) 350480 (yerli)  
(import) (native)



**Kanat sarkma takozu**  
Wing rise stopper

350485 (ithal) (import)  
350486 (yerli) (native)



**Çiftli sürgü karşılığı**  
Double keeper

350487 (ithal) (import)  
350488 (yerli) (native)



**Kanat düşüş karşılığı**  
Wing drop keeper

350489 (ithal) (import)  
350490 (yerli) (native)

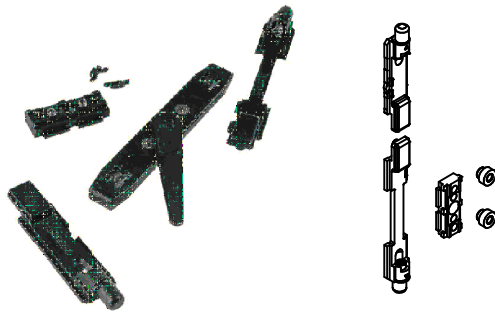

**İkinci kanat sürge seti**  
Two-way lever push bolt

350491 (ithal) (import)  
350492 (yerli) (native)

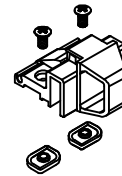

**Vasistas cıt cıt**  
Cico finger catch

350493 (ithal) (import) 350494 (yerli) (native) naturel eloksalti (mat anodized)  
350495 (ithal) (import) 350496 (yerli) (native) pres veya renkli (mill finish and painted)

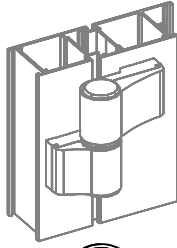

**İki yapraklı kapı menteşesi**  
Two-leaf hinges for door

350523 (ithal) (import)	350524 (yerli) (native)	naturel eloksalli (mat anodized)
350525 (ithal) (import)	350526 (yerli) (native)	pres veya renkli (mill finishand and painted)

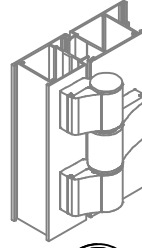

**Üç yapraklı kapı menteşesi**  
Three-leaf hinges for door

D-803 (ithal) (import)	D-803-a (yerli) (native)	naturel eloksalli (mat anodized)
D-804 (ithal) (import)	D-804-a (yerli) (native)	pres veya renkli (mill finishand and painted)

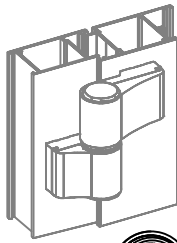

**İki yapraklı kapı menteşesi**  
Two-leaf hinges for door

350527 (ithal) (import)	350528 (yerli) (native)	naturel eloksalli (mat anodized)
350529 (ithal) (import)	350530 (yerli) (native)	pres veya renkli (mill finishand and painted)

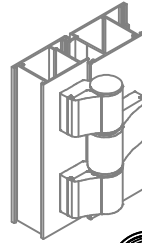

**Üç yapraklı kapı menteşesi**  
Three-leaf hinges for door

D-809 (ithal) (import)	D-809-a (yerli) (native)	naturel eloksalli (mat anodized)
D-810 (ithal) (import)	D-810-a (yerli) (native)	pres veya renkli (mill finishand and painted)

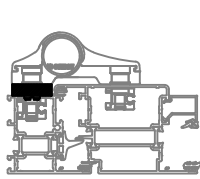

**Menteşe kademe yükseltici**  
Step for hinges

D-888 (ithal) (import)	D-888-a (yerli) (native)	naturel eloksalli (mat anodized)
D-889 (ithal) (import)	D-889-a (yerli) (native)	pres veya renkli (mill finishand and painted)

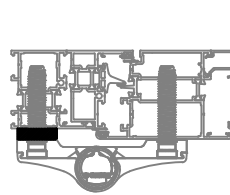

**Menteşe kademe yükseltici**  
Step for hinges

D-890 (ithal) (import)	D-890-a (yerli) (native)	naturel eloksalli (mat anodized)
D-891 (ithal) (import)	D-891-a (yerli) (native)	pres veya renkli (mill finishand and painted)

**İki yapraklı kapı menteşesi için bağlantı takımı**  
Two-leaf hinges door for counterplates

D-892 (ithal) (import)	D-892-a (yerli) (native)	naturel eloksalli (mat anodized)
---------------------------	-----------------------------	-------------------------------------

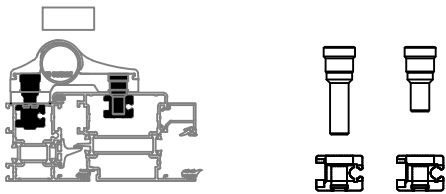

**İki yapraklı kapı menteşesi için bağlantı takımı**  
Two-leaf hinges door for counterplates

D-893 (ithal) (import)	D-893-a (yerli) (native)	naturel eloksalli (mat anodized)
---------------------------	-----------------------------	-------------------------------------

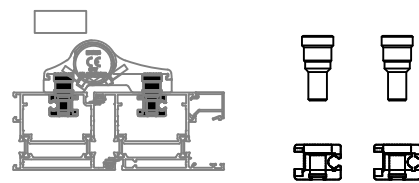

**Üç yapraklı kapı menteşesi için bağlantı takımı**  
Three-leaf hinges door for counterplates

D-894 (ithal) (import)	D-894-a (yerli) (native)	naturel eloksalli (mat anodized)
---------------------------	-----------------------------	-------------------------------------

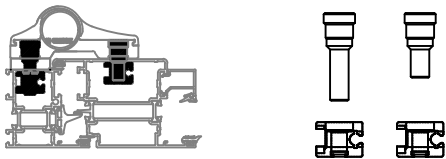

**Üç yapraklı kapı menteşesi için bağlantı takımı**  
Three-leaf hinges door for counterplates

D-895 (ithal) (import)	D-895-a (yerli) (native)	naturel eloksalli (mat anodized)
---------------------------	-----------------------------	-------------------------------------

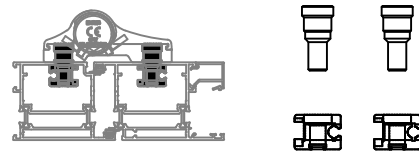

**İki ve üç yapraklı kapı menteşesi için bağlantı**

Two and three-leaf hinges door for counterplates

D-896 (ithal) D-896-a (yerli) naturel eloksalli  
(import) (native) (mat anodized)

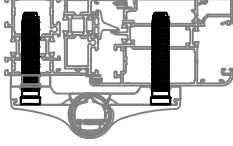

**İki ve üç yapraklı kapı menteşesi için bağlantı**

Two and three-leaf hinges door for counterplates

D-897 (ithal) D-897-a (yerli) naturel eloksalli  
(import) (native) (mat anodized)

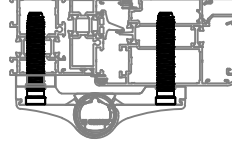

**İki yapraklı kapı menteşesi (XL)**

Two-leaf hinges for door (XL)

350531 (ithal) 350532 (yerli) naturel eloksalli  
(import) (native) (mat anodized)  
350533 (ithal) D-813-a (yerli) pres veya renkli  
(import) (native) (mill finish and painted)

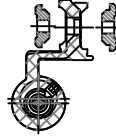

max.100 kg

**Üç yapraklı kapı menteşesi (XXL)**

Three-leaf hinges for door (XXL)

D-815 (ithal) D-815-a (yerli) naturel eloksalli  
(import) (native) (mat anodized)  
D-816 (ithal) D-816-a (yerli) pres veya renkli  
(import) (native) (mill finish and painted)

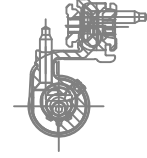

max.160 kg

**Çarpma kapı menteşesi**

Swinging door hinges

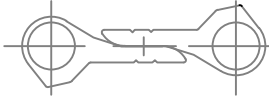

D-818 (ithal) 350534 (yerli)  
(import) (native)  
D-819 (ithal) 350549 (yerli)  
(import) (native)

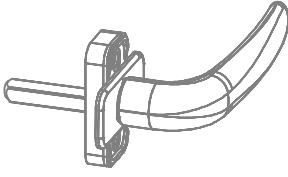

Prima kapı kolu  
Prima handle

- D-821 (ithal) D-821-a (yerli) naturel eloksalı  
(import) (native) (mat anodized)
- D-822 (ithal) D-822-a (yerli) pres veya renkli  
(import) (native) (mill finish and painted)

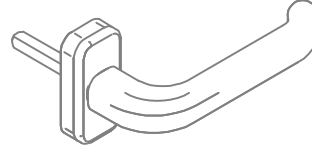

Prima kapı kolu (sağ-sol)  
Prima handle (LH/RH)

- D-824 (ithal) D-824-a (yerli) naturel eloksalı  
(import) (native) (mat anodized)
- D-825 (ithal) D-825-a (yerli) pres veya renkli  
(import) (native) (mill finish and painted)

Prima ikili kapı kolu  
Prima handle couple

- D-827 (ithal) D-827-a (yerli) naturel eloksalı  
(import) (native) (mat anodized)
- D-828 (ithal) D-828-a (yerli) pres veya renkli  
(import) (native) (mill finish and painted)

Supermaster ikili kapı kolu  
Supermaster handle-couple

- D-830 (ithal) D-830-a (yerli) naturel eloksalı  
(import) (native) (mat anodized)
- D-831 (ithal) D-831-a (yerli) pres veya renkli  
(import) (native) (mill finish and painted)

Boru kol  
Semi-circle handle

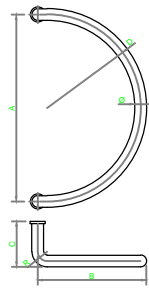

- D-833-X  
naturel eloksalı  
(mat anodized)
- D-834-X  
pres veya renkli  
(mill finish and painted)

X	Ø	R	A	B	C	D
1	20	25	110	60	55	
2	20	25	150	60	75	
3	20	25	200	60	100	
4	25	40	200	75	80	100
5	25	40	300	75	80	150
6	25	40	400	75	80	200
7	30	55	300	75	80	150
8	30	55	350	75	80	175
9	32	55	300	75	80	150
10	32	55	350	75	80	175

Boru kol  
Semi-circle curved handle

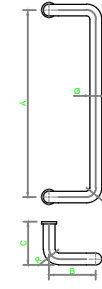

- D-836-X  
naturel eloksalı  
(mat anodized)
- D-837-X  
pres veya renkli  
(mill finish and painted)

X	Ø	R	A	B	C
1	20	25	110	90	50
2	20	25	150	90	60
3	20	25	200	90	60
4	25	40	200	100	80
5	25	40	250	100	80
6	25	40	300	100	80
7	25	40	350	100	80
8	25	40	400	100	80
9	30	40	300	100	80
10	30	50	350	130	80
11	30	50	400	130	80
12	32	50	300	150	80
13	32	50	350	150	80

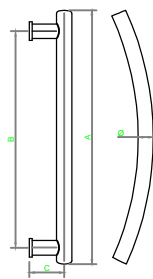

Boru kol  
Spring handle

- D-839-X  
naturel eloksalı  
(mat anodized)
- D-840-X  
pres veya renkli  
(mill finish and painted)

X	Ø	R	A	B	C
1	30	150	600	500	75
2	30	150	750	600	75

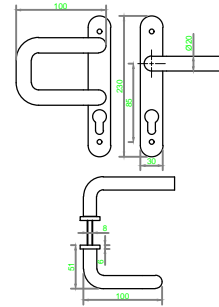

Düz-kıvrık aynalı kol  
Flat-curve mirrored handles

- D-842-X  
naturel eloksalı  
(mat anodized)
- D-843-X  
pres veya renkli  
(mill finish and painted)

Lama bant kol  
Lama stripe handle

- D-845-X  
naturel eloksalı  
(mat anodized)

- D-846-X  
pres veya renkli  
(mill finish and painted)

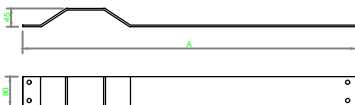

X	A
1	900
2	1000



L: 50mm

- Cam altı takozu (yerli)  
Glass support piece (native)

- D-869 W1-W2-W3-W4-D1-D2  
D65-869 W5-W6-S3  
D75-869 W7-W8  
D45-869 W9-W10

